

MUNICIPALITY OF CLARINGTON

DESIGN GUIDELINES AND STANDARD DRAWINGS



PLANNING AND
INFRASTRUCTURE SERVICES
(revised 2025)



INTRODUCTION

The Municipality of Clarington's "Design Guidelines" have been prepared by our Planning and Infrastructure Department to set out design and construction requirements. The manual will aid engineers, developers, contractors and others in the development industry.

Sections 100 to 900 of this manual provide written specifications relating to design and construction issues, while Section 1000 outlines the Municipality's Standard Drawings. The manual refers to other publications including the Ontario Provincial Standard Specifications (OPSS) and Standard Drawings (OPSD), the Transportation Association of Canada (TAC) Geometric Design Guide for Canadian Roads and the Ministry of Transportation 'Geometric Design Standards for Ontario Highways', as well as other reference publications.

Every effort has been made to ensure designs meet these standards. Where existing constraints make these impractical, written requests to modify specifications will be considered by the Deputy CAO, Planning and Infrastructure, provided the Municipality's best interests and sound engineering principles are maintained.

Furthermore, it is also understood that despite excellent design/construction methods, the final product occasionally falls short of specifications. Again, provided the best interests of the Municipality and sound engineering principles are maintained, the Deputy CAO may consider accepting such variances. Such considerations will be based on details provided to the Deputy CAO including extent of the variation, the cause and costs to correct the variation.

Should you require further information or assistance on the Design Guidelines, please contact the Planning and Infrastructure Department of the Municipality at:

Municipality of Clarington
40 Temperance Street
Bowmanville ON
L1C 3A6

Darryl Lyons, M.Pl, RPP, MCIP
Deputy CAO, Planning and Infrastructure
www.clarington.net

MUNICIPALITY OF CLARINGTON **DESIGN GUIDELINES**

Contents

Section 100—Site Plans	Page 3
Section 200—Engineering Drawing Submissions	Page 7
Section 300—Road Design	Page 13
Section 400—Storm Sewer Design	Page 16
Section 500—Stormwater Management	Page 21
Section 600—Street Lighting	Page 23
Section 700—Landscaping and Street Tree Planting	Page 25
Section 800—Lot Grading and Tree Preservation	Page 29
Section 900—Inspection, Materials and Construction	Page 36
Section 1000—Standard Drawings	

1.0 GENERAL

- 1.01 The requirements set out in this section detail the engineering requirements for site plan submissions. These requirements are in addition to any other requirements set out by other departments or authorities. Prior to approval of the site plan(s) the Developer's engineer must confirm in writing that the design has been approved by all other departments and authorities.
- 1.02 The design of the site services shall be in conformance with the Municipality's Design Guidelines and Standard Drawings and all Municipal by-laws, and in conformance with all plumbing, building and fire codes. The design must also conform to all other applicable agency requirements.

2.0 SUBMISSION REQUIREMENTS

- 2.01 Each submission shall include:
- three (3) sets of Site Plans
 - two (2) copies of storm sewer design sheets. (Pipe strengths and all other calculations relating to the design of the Works must be certified by the Developer's engineer, to the satisfaction of the Director)
 - two (2) copies of all related reports
- 2.02 Each submission shall include a covering letter outlining details of the submission and confirming that the submission reflects all site plan conditions and the Municipality's guidelines. Covering letters for resubmissions shall explain how the engineer has addressed each concern previously noted by the Municipality. Any revisions must be clearly noted in this letter to the Municipality.
- 2.03 The Municipality may return the first (or any subsequent) engineering submission to the Consulting Engineer without review, if the submission:
- is not metric or is not to scale
 - is incomplete
 - does not conform to the Municipality's design guidelines
 - does not appear to appropriately address previous comments

3.0 SITE PLAN SUBMISSIONS

- 3.01 All plans shall:
- show the name and number of the project
 - show the name/address of the applicant and Consulting Engineering firm
 - show the date the drawings were prepared
 - be prepared in hard copy, to an appropriate sized scale

- show all dimensions in metric and include a north arrow referenced on all drawings
- be stamped, signed and dated by a Professional Engineer

3.02 Each set of Site Plans shall consist of the following and shall include construction details and notes:

- Site Services Plan
- Site Grading Plan
- Landscaping Plan
- Other plans deemed necessary by the Director of Engineering Services

4.0 SITE SERVICES PLAN

4.01 The Site Services Plan shall be prepared at an appropriate scale and shall include a key location map identifying the general location. The plan shall refer to a geodetic benchmark and a site benchmark(s) and shall clearly distinguish between existing and proposed :

- storm and sanitary main/connection details, including direction of flow
- catchbasins and manholes
- ditch and culvert details, including direction of flow
- watermains, hydrants and valves
- property lines, easements, road widenings and reserves
- curbs, sidewalks and existing and proposed driveways
- all utilities, including poles and pedestals
- fencing, hedges and trees, including abutting lands
- proposed fencing, indicating height and type of fence
- proposed retaining walls, indicating type
- streets, roadways and lanes
- outline of all buildings and garages including address numbers
- basement floor elevations for proposed buildings

5.0 SITE GRADING PLAN

The Site Plans shall include a Site Grading Plan shown at a scale of 1:250. The plan shall show all above ground items required under the Site Services Plan and shall show all below ground storm sewer components. The plan shall note "Finished First Floor" and "Finished Basement Floor" elevations and shall include all dimensions, lengths, existing and proposed grades. The design shall reflect the grading requirements set out in Section 800—Lot Grading and Tree Preservation, of this manual.

6.0 LANDSCAPING PLAN

Where applicable, Site Plans shall include a Landscaping Plan shown at a scale of 1:250. The plan shall show all above ground items required under the Site Services Plan and shall be prepared by a qualified Landscape Architect. The plan shall reflect all landscaping requirements set out in the Site Plan Agreement.

7.0 OTHER

7.01 Entrances/Internal Roadways

All entrances and internal roadways shall conform to the Municipality's guidelines, including clause 5.04 in Section 300—Road Design, and shall provide:

- pavement from roadways to garages
- minimum roadway widths of 6.0m (not including street parking)
- suitable roadway widths for two-way emergency/service vehicles
- minimum radius at curb returns of 6.0m
- minimum centreline radius at bends of 15m
- vehicle turn around provisions at no exit streets or laneways
- minimum roadway grades of 1% and maximum grades of 6%

7.02 Access Permit

When access from an existing Municipal road is required, the Developer must obtain an access permit and pay all applicable monies, prior to approval of the drawings, to the satisfaction of the Director.

7.03 Electrical

The design of the electrical distribution system and the street lighting system shall be completed by a qualified electrical Consultant. The street lighting design shall conform to Section 600—Street Lighting, of this manual.

7.04 Inspection and Site Monitoring

The Developer shall monitor the site works at all times, to ensure the work is being completed correctly and that any adjacent properties and roadways are not negatively impacted. Where work is being completed within Municipal lands, the developer's Consulting Engineer shall monitor and inspect the work. Upon completion of construction, the Developer shall provide written acknowledgement that all works have been completed in accordance with the approved site plan agreement, in a form acceptable to the Director. Where deemed necessary by the Director, such written acknowledgement shall be provided

by the developer's Consulting Engineer.

7.05 Mud and Dust Control

The Developer and/or the Consulting Engineer shall monitor all adjacent roads and properties to ensure that all contractors and trades are conforming to the Municipality's Road Condition Policy.

1.0 GENERAL

This section outlines the guidelines for the preparation of all engineering submissions presented to the Municipality for approval. Prior to submitting designs for Municipal services, the Developer's engineer shall liaise with Municipal staff to obtain or clarify Municipal requirements for engineering submissions. (The Regional Municipality of Durham is the governing authority for all sanitary sewers and watermains within the Region of Durham and should be circulated on each engineering submission.)

2.0 FUNCTIONAL REPORT

The need for a Functional Report must be reviewed with Municipal staff. In cases where the proposed subdivision forms part of a larger area set aside for future development, the Functional Report shall be submitted to confirm that the servicing design does not limit future development. The Functional Report shall be required when a subdivision is being phased and the engineering design is being undertaken for each phase separately.

The Functional Report shall include proposed and existing:

- major roadway alignments, cross section and intersection
- roadway structures
- watercourse improvements, and channelization
- railway crossings
- parkland developments
- storm drainage systems including major trunk sewers
- sanitary drainage systems
- water distribution systems
- lot grading design
- pumping station locations
- stormwater management facilities/requirements
- sediment/erosion control recommendations

3.0 GENERAL REQUIREMENTS FOR ENGINEERING SUBMISSIONS

3.01 Each engineering submission shall include:

- four (4) sets of Engineering Drawings, as detailed under section 5.0
- two (2) approved Draft Plans/proposed 40M Plans noting all lots, blocks and dimensions
- two (2) sets of storm sewer design sheets, pipe strength calculations and all other calculations relating to the design of the Works
- two (2) copies of all related reports (Stormwater Management, geotechnical, etc.)

ENGINEERING DRAWING SUBMISSIONS—8

- 3.02 Each submission shall include a covering letter outlining details of the submission and confirming that the drawings reflect all draft conditions and the Municipality's guidelines. Covering letters for resubmissions shall explain how the engineer has addressed each concern previously noted by the Municipality. Each issue must be numbered to correspond to the comments issued by the Municipality. Any other changes must be clearly noted in this letter to the Municipality.
- 3.03 The Municipality may return the first (or any subsequent) engineering submission to the Consulting Engineer without review, if the submission:
- is incomplete or has not been thoroughly checked by the engineer
 - does not reflect the requirements set out in the draft conditions
 - does not conform to the Municipality's design guidelines
 - does not appropriately address previous comments
- 3.04 The design of the street lighting electrical distribution system and lighting shall be completed by a qualified electrical Consultant and shall conform to Section 600—Streetlighting Design, of this manual, and shall be submitted and approved prior to the commencement of work on the electrical system.
- 3.05 The Consulting Engineer shall obtain the approval of the Ministry of the Environment and all other applicable agencies including the Ministry of Natural Resources, Ministry of Transportation, Conservation Authorities, Fire Marshall, Medical Officer of Health, etc. The Municipality of Clarington shall be kept informed of the progress of these submissions by copies of correspondence.
- 3.06 After approvals have been received from all applicable authorities, the original drawings shall be submitted to the Municipality of Clarington for signature. Reproduction copies shall then be immediately forwarded to the Municipality (generally: two full sets, two reduced-scale sets and two sets of Lot Grading drawings). No further modifications may be made to the drawings unless through the formal submission and approval process.

4.0 ENGINEERING DRAWINGS--GENERAL

- 4.01 All final drawings shall be prepared in ink on 3 mil matte surface mylar material (A-1 594mmx841mm), and shall note:
- project name/phase, 18T number, the name/address/phone/fax and email address of the Consulting Engineering firm and the date the drawings were prepared
 - all dimensions in metric and include a north arrow referenced on all drawings
 - all proposed and existing works. Proposed, existing and future services shall be appropriately labeled and must be clearly distinguished from each other to prevent confusion (ie. dashed or hatched lines, screening, etc.)
 - no overlapping information when streets require more than one (1) plan (match lines and reference drawing numbers shall be provided)

ENGINEERING DRAWING SUBMISSIONS—9

- phase limits on all drawings
- street name and veteran poppy requirement, numbering of all blocks and lots on all engineering drawings, corresponding to the numbers shown on the Registered plan
- stamped, signed and dated by a Professional Civil Engineer. Stamps, tapes and stick-on labels shall not be used except for the Professional Engineer's Stamp (except signature and date).

5.0 ENGINEERING DRAWINGS--COMPONENTS

5.01 Each set of Engineering Drawings shall consist of the following:

- Covering Page
- General Notes Page
- General Plan of Services
- Plan and Profile Drawings
- Lot Grading Drawings
- Tree Inventory/Preservation Plans
- Storm Drainage Plan
- Stormwater Management/Silt Control Plan
- Street Furniture/Utility Plan
- Detail Drawings

5.02 Covering Page

The Engineering drawings shall include a Covering Page which includes an index to the drawings and an overall key map outlining each drawing area.

5.03 General Notes Page

The Engineering drawings shall include a General Notes page showing:

- a list of all applicable specifications, road pavement designs, and any other pertinent information relating to the construction and installation of services
- geodetic bench marks, referenced and described and all datum shall relate to this bench mark. Where established, site bench marks shall be described and detailed
- legend defining all symbols used on the drawings

5.04 General Plan of Services

The Engineering drawings shall include a General Plan of Services drawing, prepared at a scale of 1:1000, which shows all existing and proposed:

- storm and sanitary mains, including direction of flow
- catchbasins and manholes (including numbers)
- ditches and culverts, including direction of flow
- diameter, length and grade of all pipes

ENGINEERING DRAWING SUBMISSIONS—10

- stormwater management ponds and channels
- watermains, hydrants and valves
- road allowances, pavement widths, easements, road widenings and reserves
- curbs, sidewalks and existing driveways
- all building lots, park, school and open space blocks
- utilities, including poles and pedestals
- driveways, fences, hedges and trees for abutting lands
- adjacent lands and land uses that may impact the design
- proposed fencing, indicating height and type of fence
- proposed retaining walls, indicating type
- Canada Post community mailbox facilities

If applicable, future roads and services shall be shown and labeled. Streets shall be named, lots and blocks to be numbered and described (type).

5.05 Plan and Profile Drawings

The Engineering drawings shall include Plan and Profile drawings, prepared at a scale of 1:500 horizontal, 1:50 vertical. The drawings shall show all items required under General Plan of Services, including all dimensions, lengths, grades and elevations, in addition to:

- any additional proposed or existing items that may impact the design or installation of the works
- existing and proposed centreline road grades at intervals not exceeding 25 metres. Any vertical or horizontal change in direction, including chainages, all vertical and horizontal curve data, gutter grades around corners and all existing and proposed ditch grades
- all water, sanitary and storm sewer service connections to all lots and blocks. Different line symbols shall represent each type of service
- proposed minimum pavement design
- the profile portion of the drawing shall be a vertical projection of the plan whenever possible and shall be drawn to scale to show all pipe and manhole details, including material, class, size, bedding, safety grates, etc.
- hydraulic grade line. Show basement elevation clearances where critical.
- all manholes shall be identified by number on the plan and on the profile and shall also be referred to the applicable Municipal Standard Detail Drawing or to a special detail on the profile portion of the drawing. All invert elevations shall be shown on the profile with each having reference to the north arrow
- all catch basins and catch basin connections
- all plans and profiles shall include key maps in the upper right corner, highlighting the section of roads covered by such drawing. Generally, each plan and profile shall be prepared such that each street may be separately filed.
- all pipe crossing elevation details

ENGINEERING DRAWING SUBMISSIONS—11

5.06 Lot Grading Drawings

The Engineering Drawings shall include Lot Grading Drawings shown at a scale of 1:500. The drawings shall show all items required under General Plan of Services, including all dimensions, lengths, grades and elevations, in addition to the requirements set out under Section 800—Lot Grading and Tree Preservation, of this manual.

5.07 Tree Inventory/Preservation Plans

The Engineering Drawings shall include a Tree Inventory and Tree Preservation Plan shown at a scale of 1:500, as per Section 800 of this manual.

5.08 Storm Drainage Plan

The Engineering Drawings shall include a Storm Drainage Plan shown at a scale of 1:1000. All storm drainage plans shall clearly outline the drainage tributary area for each manhole, including the area and runoff coefficient, and the overland flow routes.

5.09 Stormwater Management/Sedimentation Control Plan

The Engineering Drawings shall include a Stormwater Management Plan when applicable, and Sedimentation Control Plan. These separate plans shall detail all of the permanent stormwater management works, in accordance with Section 500—Stormwater Management Facilities, of this manual, as well as the interim methods which will be implemented to control sediment. The plan shall include all detail drawings and shall also note the recommended schedule and method of maintenance and cleaning of such controls.

5.10 Street Furniture and Utility Plan

The Engineering Drawings shall include a Street Furniture/Utility Plan showing all sidewalks, in addition to all street lights, street trees, Bell Canada, Hydro and other utility pedestals, hydrants and any other above ground works within the boulevard area.

5.11 Detail Drawings

The Municipality of Clarington Design Guidelines and Standard Drawings shall be used as a first source of reference, and shall be reproduced as part of the Engineering Drawings. Where such Guidelines or Standard Drawings do not address an issue, The Ontario Provincial Standard Specifications and Drawings may be applied, upon approval and at the discretion of the Director. Where designs require custom specifications, they shall be prepared and stamped by an engineer and approved by the Municipality, and clearly shown on the engineering drawings at a suitable scale such as 1:50 for sewers or manholes.

ENGINEERING DRAWING SUBMISSIONS—12

6.0 'AS BUILT' DRAWINGS

- 6.01 The original drawings shall be revised to reflect as-constructed dimensions submitted to the Municipality for our permanent records. The drawings shall reflect field verification of the following items:
- location, length, invert/lid elevations, grade and pipe capacity for all sewer mains including , rear yard catchbasin leads, sewer stub lines, manholes and catchbasins
 - location of all curbs and sidewalks
 - road centre line profile
 - location of all hydrants, valve boxes, and utility poles and pedestals
 - any other items which may be necessary
 - verification of benchmark

Upon submission of the as-built drawings, the engineer shall confirm that all as-built information reflects the proper design of the works and that any discrepancy between design and as-built is minor in nature and does not affect the design of the works. Where this cannot be confirmed, the engineer shall submit the necessary details to the Director. Upon review, the Director shall either approve such variance between design and as-built measurements, or shall direct that the works be corrected to conform to design.

- 6.02 All as-built drawings to be submitted in digital format, in a manner acceptable to the Director.

1.0 GENERAL

- 1.01 The design and construction of all roadways shall be in accordance with the Municipality of Clarington's Design Guidelines and Standard Drawings. Where these specifications do not address an issue, reference should be made to the latest Geometric Design Guide for Canadian Roads, Transportation Association of Canada (TAC) Manual, including Urban Supplement, and the Ministry of Transportation 'Geometric Design Standards for Ontario Highways'. The appropriate application of any specification shall be at the sole discretion of the Director.
- 1.02 Road classifications, right of way and pavement widths shall be determined by the Director and shall reflect the approved Draft Plan of Subdivision.
- 1.03 Refer to the Municipality's Standard Drawings for typical roadway cross section details.
- 1.04 Sidewalks shall be located in accordance with the Municipality's current guidelines and shall be based on a neighbourhood plan denoting the various land uses.
- 1.05 Additional requirements such as turning lanes, tapers, signalization, signs, line painting, traffic calming devices, etc. shall be provided to the satisfaction of the Director.

2.0 PAVEMENT DESIGN

- 2.01 Pavement design shall reflect the Soils Report, carried out by an approved geotechnical engineering firm, to the satisfaction of the Director, and shall be based on:
- mechanical analysis of the subgrade soil
 - frost susceptibility
 - drainage
 - traffic volumes
- 2.02 The final pavement design shall be determined solely by the Director and in no case shall be less than the applicable minimum pavement designs shown on the Municipality's Standard Drawings.

3.0 GEOMETRIC DESIGN

- 3.01 Every effort shall be made to ensure roads intersect at right angles and roads shall not have acute angles.
- 3.02 Unless noted otherwise, local roads shall have a design speed of 50 km/h while collector roads shall have a design speed of 60 km/h. Road design parameters shall be based on specifications and guidelines set out under item 4.0 of this section.

- 3.03 On low volume roadways such as cul-de-sacs and short crescents, design parameters may be amended at the discretion of the Director.

4.0 ADDITIONAL ROAD ALIGNMENT DESIGN DETAILS

4.01 Horizontal/Vertical Alignment and Grades:

- Where the Municipality of Clarington Design Guidelines do not address a road design aspect, the following publications (in order) shall provide suitable design considerations, to the approval of the Director: a) *Geometric Design Guide for Canadian Roads*—Transportation Association of Canada (TAC); and b) Ministry of Transportation *Geometric Design Standards for Ontario Highways*.
- Maximum centreline road grades shall be 6.0% for local roads and 5.0% for collector roads. Minimum centreline road grades shall be 0.5%; however, ditch grades must maintain 1% minimum, and must ensure downstream ditches have similar gradient to accommodate the proposed project. Where 1.0% minimum ditch grades cannot be consistently maintained, or where deemed appropriate by the Director, alternative designs must be employed, including semi-urban curbing.
- Minimum curb gutter grade is 0.5%. Curb grades along outside corners and cul-de-sacs shall be shown at 10 metre intervals and shall maintain 1% grades minimum.
- Cul-de-sacs shall have of 2.0% minimum crossfall, and maintain minimum gutter grades of 1.0%.
- Vertical road grade changes in excess of 1.5% shall be designed using vertical curves, as outlined in the Ministry's "*Geometric Design Standards for Ontario Highways*". Intermediate grade points shall be calculated every 5 metres and shown on the profile along with all vertical curve data such as the 'K' Factor, length of curve, tangent grades and all points of intersection. (For local roads use minimum K values of 10 for crest, 12 for sag). Spline grades shall be at 5 metre intervals. Where proposed road grades are not identical to existing road grades, appropriate transition lengths shall be employed.
- A 1% to 2% backfall grade should be provided where local or collector roads intersect with collector or arterial roads.

4.02 Miscellaneous Design Details:

- All road surfaces shall maintain a crossfall of 2% to the front edge of curb. No superelevation shall be used.
- Temporary turning circles shall be provided where the road is to be extended in the future, unless no building lots front that portion of terminated roadway. The turning circle shall be designed to fit within the right of way and may require 3.0m snow storage easements along the perimeter. Any lots abutting the turning circle shall not be issued building permits until the road is extended through.

- Sidewalks and walkways shall be located for optimum effectiveness, as directed by the Municipality. Sidewalks shall run parallel to curbs and shall be a minimum of 1.5m in width. Greater widths may be considered in areas of high pedestrian activity. Generally, sidewalks are required on both sides of collector roadways and one side of local roadways. On cul-de-sacs of less than 120 metres, sidewalks are not required unless providing a pedestrian link.
- Sight triangles shall be provided as per Section 2.3.3 of the TAC manual.
- Curb radii to be 7.5m for local intersections and 9.0m for any collector road intersection. Greater radii to be provided in commercial/industrial/transit areas.

5.0 ENTRANCES

5.01 All driveways must be aligned perpendicular to the road and skewed entrances are not permitted. Driveways shall not cross property line projections. Urban driveways shall be straight projections of the garage to the curb with design widths as follows:

Single detached residential	4.6m min to 6.0m max
Semi-detached/link	4.6m
Townhouses	3.0m

Designs for wider driveways will be considered for semi-detached (6.0m max) and for townhouses (4.6m max) provided that on-street parking is not affected and provided that sufficient snow storage remains between properties.

5.02 Driveways shall not be located closer than 7.5m from the near street line at intersections.

5.03 Urban/rural driveway grades shall be designed between 2% and 8%. Commercial, industrial and institutional driveways shall be designed between 2% and 6%. Due to the imprecise nature of house construction, actual as-built grades may vary from the approved design. However, when requested, the Consulting Engineer must certify that the driveway has consistent positive drainage to the street and that it does not exceed a grade of 10%.

5.04 Commercial/Industrial entrances shall provide a radius at the existing roadway (with concrete curbing where deemed appropriate) and shall consist of following:

	<u>Commercial/Institutional:</u>	<u>Industrial:</u>
Entrance width (min—max)	6.0m—9.0m	6.0m—9.0m
Entrance radius (min—max)	6.0m—9.0m	9.0m—12.0m
HL3	40mm	40mm
HL8	50mm	80mm
Gran. A	150mm	150mm
Gran. B	300mm	375mm

1.0 GENERAL

- 1.01 The watershed area shall be determined from contour plans and shall include all areas that naturally drain into the system and shall also consider all lot grading plans for proposed developments.
- 1.02 A Drainage Plan of the watershed area shall be prepared and shall include all affected streets, lots and watercourses. The proposed storm sewer system shall be shown on this plan including each manhole numbered consecutively for design reference.
- 1.03 Manholes shall be the tributary points in design. The areas tributary to each manhole shall be clearly outlined on the storm drainage area plan with the area in hectares (to the nearest tenth) and runoff coefficient shown below, drawn in a 15mm diameter circle.
- 1.04 In cases where areas of different runoff coefficients are tributary to one manhole, the areas tributary to the manhole shall be individually outlined. Tributary areas to manholes must address the proposed grading of lots and blocks.
- 1.05 In the case of large tributary areas under single ownership, such as shopping centres, apartment developments, schools, etc., the design shall be prepared on the basis of the whole area being tributary to a manhole in an abutting storm sewer. When more than one sewer connection will be necessary to serve the property in question, the appropriate area tributary to each sewer connection shall be clearly shown and taken into account in the design of the storm sewer.
- 1.06 In lieu of precise information on development of the whole or any part of a watershed area, the latest approved Zoning By-law and Plans shall be used to select the correct values of the runoff coefficients to be used in the design and to determine the specific areas where they will apply.
- 1.07 The Director shall maintain sole authority in determining appropriate drainage areas, rainfall intensity, runoff coefficients and other storm sewer design factors.

2.0 GENERAL STORM SEWER DESIGN REQUIREMENTS

- 2.01 The location and design of all storm sewers, manholes, connections, catchbasins and structures, and their related bedding requirements, shall be as per the Municipality's Standard Drawings and the approved engineering design drawings.
- 2.02 All blocks and parcels of land shall be fully serviced for their potential development.
- 2.03 Roof water leaders shall not be connected to municipal storm sewers except with townhouses, where such connections shall be directly to the storm sewer main. Foundation drains shall be connected to municipal storm sewers and shall be protected

STORM SEWER DESIGN—17

with a minimum 0.5m freeboard against surcharging for major storm events.

- 2.04 Provide calculations showing that major storm flooding does not encroach onto private property and depth of water at centreline of collector roads will not exceed 0.15m.
- 2.05 The minimum depth of cover on all storm sewers and connections shall be 1.2 metres, although 1.8m is preferred. Storm sewer connections (laterals) shall be of suitable depth to accommodate house foundation drains.
- 2.06 Except where approved otherwise, storm sewers shall maintain a 3 metre horizontal separation from sanitary sewers and shall generally be located at a 1.5m offset from the roadway centreline.
- 2.07 Sewers shall extend to the subdivision limits to provide for future connection.
- 2.08 Radius pipe must be specifically approved by the Municipality and will not be permitted for pipe diameters of 750mm or less. Elbows will not be permitted for sewer mains nor are manhole 'tees' generally permitted.
- 2.09 In no case shall a downstream pipe be smaller than the upstream pipe, regardless of the increase in grade.
- 2.10 All house connections shall extend 1.5 metres into the lot. No "Y" connections are permitted. Pre-manufactured tees are required for sewer mains 450mm and smaller. All larger mains require coring using approved equipment.

3.0 PIPE CAPACITY DESIGN

- 3.01 All storm sewer design calculations must be submitted to the Municipality for review on standard design sheets.
- 3.02 Yarnell's rainfall intensity/duration curves shall be used for the minor storm sewer design.

Design Storm	Yarnell Rainfall Intensity Formulas (Metric)
1:2 Year	$I = 1778/Tc + 13$
1:5 Year	$I = 2464/Tc + 16$
1:10 Year	$I = 2819/Tc + 16$
1:25 Year	$I = 4318/Tc + 27$
1:50 Year	$I = 4750/Tc + 24$
1:100 Year	$I = 5588/Tc + 28$

Note: For 1:100 year storm event, the Chicago Storm formula should be used to be more conservative. i.e. $I = 1770 / (Tc + 4)^{0.820}$

STORM SEWER DESIGN—18

3.03 Storm sewers shall be designed using the Rational Formula as follows:

$$Q = 2.78 AIR$$

Where Q= Runoff quantity in litres/second (l/s)

A= Area in hectares (ha)

I = Average rainfall intensity in mm/hour (mm/h)

R= Runoff coefficient

3.04 Runoff coefficients shall be used based on land use as follows:

- Commercial lands = 0.90
- Industrial lands = 0.80
- Schools = 0.70
- Townhouses = 0.65
- Semi-detached/link = 0.55
- Single family residential = 0.50
- Parks, open spaces, cemeteries = 0.20

3.05 Manning's Formula shall be used to determine storm sewer capacity. Pipes are to be considered flowing full, with a minimum entry time of 15 minutes used. Tables for "Capacity and Velocity of Circular Pipes by Manning's Formula" shall be used in conjunction with the design criteria.

3.06 Roughness coefficient shall be $n=0.013$ for all pipes except Corrugated Steel Pipe (CSP) which shall use $n=0.024$.

3.07 Storm sewer velocity to be minimum 0.98 metres/second (m/s) and maximum 5.0 m/s.

3.08 Minimum pipe gradient shall be 0.5%. Grades flatter than 0.5% may be permitted under extreme conditions, at the discretion of the Director.

3.09 Minimum pipe size for storm sewer mains and rear yard catchbasin leads shall be 300mm. Exceptions may be made for Foundation Control Drain systems, where permitted by the Director.

4.0 PIPE STRENGTH DESIGN

4.01 Storm sewer mains and rear yard catchbasin leads shall be concrete, conforming to CSA Specification A257.2, and all concrete products shall be certified for compliance under the Plant Prequalification Program, as approved by the Director.

4.02 Road catchbasin leads shall be solid wall PVC (SDR 35) and house service connections PVC (SDR 28), conforming to all CSA Specifications including B182.1 and B182.2.

STORM SEWER DESIGN—19

- 4.03 Road culverts to be corrugated steel pipe (CSP), 2.0mm thickness, aluminized coated. Where riveted pipe is not supplied, any problems with spiral pipe during handling, installation and backfilling (such as split seams), will be the responsibility of the supplier/contractor. Culvert lengths exceeding 25 metres require access manhole at midpoints. Culvert lengths exceeding 25 metres require access manhole at midpoints.
- 4.04 All sewer pipes shall be designed for dead loading (present and ultimate future) and live loading Highway H-20 Loading, regardless of the location of the sewer, except when the sewer crosses a railroad, in which case Railway E-80 loading shall govern. Factors such as soil conditions, pipe bedding, trench width and depth of sewer shall be considered when determining the appropriate pipe strength. All sewers to be designed using OPSD criteria for Positive Projection Embankment conditions.

5.0 MANHOLES

- 5.01 Where the Standard Drawings cannot accommodate a particular manhole or structure in size or layout, the structure shall be custom designed by a structural engineer, and submitted to the Municipality, with all supporting calculations, for approval.
- 5.02 Manholes shall be provided at all changes in sewer alignment, pipe sizing or pipe grade and at all sewer junctions, including rear yard catchbasin leads.
- 5.03 Maximum spacing of manholes for sewer sizes up to 1200mm diameter shall be 110 metres. Larger pipes may have manholes spaced up to 150 metres apart.
- 5.04 Pipe sizes of 1050mm diameter and larger shall not be turned more than 45 degrees in any manhole.
- 5.05 For standard manholes, the minimum drop across the manhole shall be 20mm on straight runs, 50mm where flows turn 45 degrees and 80 mm where flows turn more than 45 degrees. In no case shall the obvert of the downstream pipe be higher than the obvert of the upstream pipe.
- 5.06 Manholes located outside of roadway limits (or within proposed roadways that are part of future development) require lockable style lids, to the satisfaction of the Director.
- 5.07 The minimum outside clearance between pipes at crossings shall be 150mm, except where additional clearance is dictated by other agencies.
- 5.08 Safety grates shall be installed in manholes exceeding 5.0 metres in depth, and shall be located such that a minimum of 1.8m headroom is provided.
- 5.09 Manholes for storm sewer pipes 450mm and smaller shall be benched to springline. Manholes for larger pipes shall be benched to obvert on a straight projection from the springline, unless approved otherwise. Benching surfaces shall not exceed 10%.

STORM SEWER DESIGN—20

- 5.10 Manhole designs with sumps may be permitted in some cases, upon approval of the Director.
- 5.11 Every effort shall be made to minimize the difference between upstream and downstream invert elevations in manholes. Where this difference exceeds 1.2m, a drop structure will be required.

6.0 CATCHBASINS

- 6.01 Generally, the maximum spacing between road catchbasins or from a catchbasin to a highpoint shall be 75 metres. Catchbasins shall also be located at the point of curvature on the upstream side of all curb returns and shall also be located upstream of sidewalk crossings and walkways. Every effort should be made to avoid locating catchbasins within driveway entrances.
- 6.02 Road catchbasin leads to be 200mm diameter (single) and 250mm (double) solid wall PVC while rear yard catchbasins to be 300mm concrete.
- 6.03 All rear yard catchbasin leads shall be connected directly to manholes at the street.
- 6.04 Rear yard catchbasins to have sumps filled with concrete to pipe invert to eliminate standing water.
- 6.05 Double catchbasins required at all low points, except where flow from one direction is minimal.
- 6.06 Inlet Control Devices (ICD's) shall be shown on the drawings, when applicable.

7.0 OUTFALLS

- 7.01 Headwall designs shall reflect the principles of OPSD 804.04 (804.030 not permitted) and shall incorporate proper handrailings along top and wingwalls, and headwall gratings as an integral part of the structure, or as approved by the Director.
- 7.02 In urban areas, rip rap shall not be used due to the ease of removal/vandalism. Alternative materials and methods shall be employed. All erosion control materials shall be placed on top of an approved filter fabric. Channels shall be designed to meet existing watercourses at 45 degrees or less.

1.0 GENERAL

- 1.01 These criteria are to be applied in conjunction with the latest revision of the MOE Stormwater Management Practices—Planning and Design Manual 2003, in addition to the requirements of the local Conservation Authority and any other applicable regulatory agency.
- 1.02 Stormwater management aspects shall be fully investigated by the Consulting Engineer with respect to conformance to the Master Drainage Plan, including existing downstream facilities and future upstream capacity requirements. Every effort must be made to minimize the overall number of municipal facilities by maximizing capacity and in this regard, the required capacity and drainage area shall be as determined by the Director.
- 1.03 Stormwater management facilities should be compatible with abutting land uses and are preferred in proximity to valley lands, where they can blend into the natural appearance. Where permanent water depths are not a concern, there may be merit to locating facilities adjacent to parks. However, facilities are not generally preferred adjacent to parks, schools or other similar public areas.
- 1.04 The design of stormwater management facilities must address safety considerations, ease of municipal access, low maintenance and overall aesthetics and efficiency, in addition to the necessary stormwater quantity and quality requirements.

2.0 DESIGN PRINCIPLES

- 2.01 A gravity by-pass pipe shall be provided to allow the pond to be drained for emergency/maintenance work. The intake for the by-pass pipe shall be at the invert of the pond, with a sump provided to protect it from clogging. Such systems shall include a lockable control gate valve. Flow controls should include orifice plates which can be removed in cases of emergency.
- 2.02 Landscaping of facilities shall be in accordance with the requirements set out in Section 700—Landscaping and Street Tree Planting, of this manual. A separate Stormwater Management Landscaping Plan shall be submitted to the Municipality for approval.
- 2.03 Buffer strips around the perimeter of all facilities shall be provided. Such buffers shall be 6.0m minimum width.
- 2.04 A 3.0m wide planting shelf with a slope of 7:1 shall be provided along the permanent water's edge (1.5m above and 1.5m below). All other sloping above the planting shelf shall not be steeper than 4:1 while sloping below the planting shelf may not exceed 3:1. Gentler slopes shall be provided where possible.
- 2.05 Maximum water levels to be according to the MOE manual, as approved by the Director.

STORMWATER MANAGEMENT—22

- 2.06 All inlets and outlets of ponds shall be suitably protected against erosion.
- 2.07 Fencing of stormwater facilities shall be determined on a project by project basis. As a general guide, 1.8m chainlink fence shall be installed abutting residential lots, school blocks, park blocks or other similar public lands while it may not be required abutting municipal roadways, permanent open space lands, EPA lands or other similar passive lands. Alternative fencing styles may also be required.
- 2.08 Maintenance access, including the boulevard portion, shall be a minimum of 5.0m wide, 300mm compacted Granular A, and may require surfacing with minimum 50mm HL3 or other suitable surface. Grades shall not exceed 10% and crossfall shall not exceed 2%. Access must extend directly to the sediment forebay and should also be provided to the outlet/inlet structures. All accesses must include a method for municipal vehicles to safely turn around at their limits. A curb depression shall be provided at the street connection, and suitable means of preventing public vehicular access shall be provided.
- 2.09 Warning signs shall be located near public roadways, walkways and in other conspicuous areas, as determined by the Municipality. Signs vary in size, wording and number, based on the uniqueness of the facility. All signs shall meet municipal requirements and must be ordered and purchased through the Municipality's Operations Department.
- 2.10 Sediment forebays and the working area directly abutting sediment forebays shall incorporate a suitable working mat to provide machinery support and access. Depending on the size of the facility, an additional designated drying area for removed silt may be required adjacent to the sediment forebay.
- 2.11 Where required, berming around the perimeter of the facility shall be designed with a minimum 3.0m top width. Top elevations of berms shall provide no less than 300mm freeboard above the highest water level. Designs must not incorporate the use of retaining walls below the top of berm elevation.
- 2.12 Maintenance manuals shall be provided for each facility, outlining the proper methods and frequency of maintaining that particular facility, during the maintenance period and after assumption of the facility by the Municipality. Immediately prior to assumption of the facility by the Municipality, the sediment forebay and any other affected areas shall be cleaned and all material disposed of off site at the Developer's cost.

1.0 GENERAL

- 1.01 Illumination shall be provided on all roadways and all walkways serving as direct street to street pedestrian links, within and fronting new developments. Illumination shall be in accordance with the latest edition of RP-8 American National Standard Practice for Roadway Lighting, Clarington guidelines and to the satisfaction of the Director.
- 1.02 The streetlight design shall be created by photometric analysis using industry standard software, as approved by the Director. All components such as pole style and height, length of bracket arm, luminaire style, wattage, etc. to be supplied to the satisfaction of the Director.
- 1.03 The Developer's Electrical Engineer shall submit a Lighting Plan which shows the following:
- proposed light pole locations
 - disconnect pedestal locations
 - bulb wattage
 - distribution type
 - wire sizes
- 1.04 All electrical codes, including the requirements of the local hydro utility, shall be followed, in addition to the requirements noted herein. Installation of the works shall be inspected by the Developer's engineer and the Electrical Safety Authority (ESA).

2.0 LUMINAIRES

- 2.01 High pressure sodium luminaires shall be used for all roadway and walkway illumination.
- 2.02 All luminaries shall have individual photocontrols.
- 2.03 Roadway fixtures shall be Cooper OVH or approved equivalent. Walkway luminaires shall be Cooper RC fixtures or approved equivalent.
- 2.04 Lenses for roadway fixtures shall be glass and walkway fixtures shall be flat polycarbonate.
- 2.05 On steeper grades, luminaires to be rotated to provide even lighting of pavement.

3.0 BRACKETS

- 3.01 For roadways, only tapered elliptical aluminum arms shall be used, installed so that the fixture hangs over the near curbline.
- 3.02 Walkway lighting shall come complete with brackets compatible with the walkway design and as specified by the light manufacturer, as approved by the Director.

4.0 POLES

- 4.01 Street light poles shall be StressCrete or approved equivalent, direct buried, spun concrete and grey in colour, as approved by the Director.
- 4.02 Walkway light poles shall be StressCrete or approved equivalent, direct buried, spun concrete and coloured as directed by the Director.
- 4.03 Road widths of 14.5m or wider require street lights to alternate on both sides of the street.

5.0 STREETLIGHT DISCONNECTS

- 5.01 For use with standard streetlight poles, the streetlight disconnect shall be the Ferraz Shawmut EP 130-30 or approved equivalent, having a service entrance rating to suit ESA (Electrical Safety Authority).
- 5.02 Each disconnect shall be securely mounted onto a streetlight pole, 1.8m above finished grade, meeting ESA requirements.
- 5.03 For use with decorative streetlight poles, the streetlight disconnect shall be the Reltec TV 1024 with a Square D, CQO Load Centre, Series S1, Type 1 enclosure or approved equal having a service entrance rating to suit ESA.
- 5.04 Each individual circuit, within a disconnect, will feed a maximum of six (6) streetlights.

SECTION 700 LANDSCAPING AND STREET TREE PLANTING—25

1.0 STREET TREES--GENERAL

Street trees shall be planted along all roadways within and fronting new developments and shall provide screening where required. The Street Tree Plan (Landscape Drawing) shall be prepared and submitted by the Developer's Consulting Engineer for the Director's approval. The Plan shall show proposed tree locations and species and shall include the Clarington Deciduous Tree Planting Detail and complete plant list.

Final quantities and locations will be determined by the Municipality at the time of stake out. The Developer's landscaper is to follow all specifications for nursery stock as outlined in the Canadian Nursery Trades Association handbook as it pertains to deciduous trees, in addition to these specifications.

All precautions must be taken with respect to the location and care of underground utilities. All utilities and driveways must be shown on the planting plan. Driveway locations should be shaded to differentiate between sodded areas.

2.0 PLANTING RESTRICTIONS

2.01 Every effort shall be made to accommodate a minimum of one tree per lot, provided there is sufficient space and clearance. Trees should generally adhere to the following clearances:

- 18 metres from the face of any traffic control sign
- 15 metres from any other intersection corner
- 5.0 metres from any lamp standard
- 1.5 metres from any hydro transformer
- 1.5 metres from any water hydrant or edge of driveway
- 7.0 metres from any other tree (taking into account the species of the trees)

2.02 Trees planted below utility lines must be small crowned with a low maximum height.

2.03 Street tree planting design should follow these guidelines;

- Where tree spacing exceeds 10m, trees with a large crown should be used to maximize visual impact.
- Where spacing is less than 10m, medium or small crowned trees should be used.
- Visual uniformity in the streetscape is important. No more than three different tree species should be used in an alternating pattern along the block of a single street. The trees should have similar height and form.
- A single variety of tree may be used along the length of a block or an entire short street.
- The use of hardy native trees is encouraged.

LANDSCAPING AND STREET TREE PLANTING—26

- The use of Norway Maple cultivars should be limited or avoided. They may be used only as a small percentage of the overall plan and never adjacent to natural areas such as woodlots and valleys.
- Due to the threat of Emerald Ash Borer, no Ash (*Fraxinus*) will be permitted.

3.0 SPECIFICATIONS FOR TREE STOCK

- 3.01 All deciduous trees shall have a minimum trunk caliper of 60mm (BHD). On Arterial type roadways or common boulevards the trunk caliper size shall be 75mm.
- 3.02 All trees shall have a reasonably straight trunk, free of any decay or wounds.
- 3.03 The tree shall have a balanced canopy with a minimum of 12 branches. The branching height shall be a minimum of 1.8 metres from root ball.
- 3.04 Columnar trees shall possess one main trunk and no multiple competing stems. Branching shall be uniform and characteristic of the growth habit for the specie.
- 3.05 The root ball shall be a minimum of 750mm in diameter and shall have a depth of 2/3 of the diameter. The root ball must be solid with little or no movement at the trunk and free of girdling roots.

4.0 SPECIFICATIONS FOR TREE INSTALLATION

- 4.01 Prior to any trees arriving on site, an onsite meeting between the landscaper, contractor, Developer's Landscape Architect and Municipal Staff must be held to review planting locations and procedures.
- 4.02 The Developer's landscaper shall ensure that trees are planted under ideal seasonal conditions and according to the following procedures.
- 4.03 All tree pits shall be prepared in accordance with Clarington Tree Planting Detail C-508.
- 4.04 Trees shall be placed so that the root flare is 50mm above the finished boulevard grade. Sub-grade levels will not be accepted. The ball or basket must be untied with the trunk free from choking ties. All trunk wrap must be removed after planting. The top 1/3 of the wire basket and burlap must be removed, (not bent downward). The remainder of the basket must be clipped randomly throughout the remaining 2/3. Waste from these procedures shall be properly disposed of off site.

The hole shall be backfilled halfway with a blended mix of topsoil. Topsoil to consist of 5 parts dark loam, 2 parts composted cattle manure, 1 part beach washed sand, and 1 part peat moss. .50 kilos of bonemeal 2-22-0 per m³ of soil blend will also be added. The hole shall then be backfilled and compacted to remove all air pockets and to ensure the tree is stable without the installation of tree stakes.

LANDSCAPING AND STREET TREE PLANTING—27

The planting pit surface shall be mulched with a minimum of 75mm of shredded bark mulch. Wood chips will not be accepted. Mulch must not be placed against the trunk of the tree.

5.0 TREE AND MATERIAL INSPECTION

- 5.01 The Municipality reserves the right to investigate, inspect and reject any substandard material, tree or procedure at any time during, or subsequent to, the planting process.
- 5.02 Immediately following planting, each tree shall be inspected for damage. Damaged trees shall be replaced or treated in accordance with proper horticultural standards, as directed.
- 5.03 The Developer's landscaper shall implement an ongoing maintenance program for all trees and shall monitor their progress at 3 and 12 months. Any trees showing signs of distress shall be treated or replaced immediately, as directed.

6.0 STORMWATER POND PLANTING

- 6.01 A Landscape Plan shall be submitted to the Municipality for approval, and shall show plantings with a variety of native trees and shrubs with the goal of creating a natural looking wetland environment. Any staging of planting shall be noted on the plan.
- 6.02 Deciduous tree caliper size shall vary from 45mm to 60mm with an equal distribution of each size.
- 6.03 Coniferous trees shall vary in size from 1000mm high to 1800mm high.
- 6.04 Cuttings can be used for shrub planting but not exclusively. Potted shrubs should also be used. All shrubs shall be planted in continuous mulched beds.
- 6.05 Pond banks shall be seeded with a low growing seed mixture of trefoil clover and Italian rye grasses. All slopes 3:1 or greater require an erosion control fabric to hold the slope for the grow-in period. The fabric shall be either bio-degradable or a neoprene product that will not be visible after grow-in.

7.0 PARK BLOCK REQUIREMENTS

- 7.01 Park Blocks shall be conveyed to the Municipality free of any garbage, debris, or building ruins.
- 7.02 Park Blocks shall not be used to stockpile topsoil or to store any material whatsoever.

LANDSCAPING AND STREET TREE PLANTING—28

- 7.03 Park Blocks shall not be stripped of topsoil, graded or filled, or cleared of any vegetation without prior approval from the Municipality.
- 7.04 Park Blocks shall have hydro, water and storm sewer lines stubbed and capped at a point inside the park property line. The location of the services along the park frontage will be established by the Municipality.
- 7.05 To ensure pedestrian and vehicular access to park sites, even when located in a future phase of subdivision development, the road and sidewalk to the park frontage shall be provided at the Municipality's request. The timing of park construction will be established by the Municipality.

1.0 GENERAL

The grading design for all lots and blocks shall include the following:

- investigate and maintain existing drainage of adjacent lands
- self contain storm drainage within the subdivision limits
- maintain positive drainage (minimum 2%) at all times
- optimize use of land
- minimize use of rear yard catchbasins and retaining walls
- direct all drainage flows away from houses
- provide for safe overland routing of "Major Storm" flows
- preserve trees/vegetation where feasible

2.0 MASTER LOT GRADING PLAN

2.01 Drawing Size = A1 (594 mm x 841 mm)

Scale (Metric) = 1:500 for single family/semi-detached areas, 1:200 for multi-family

2.02 The following shall be shown on the Master Lot Grading Plan:

- north arrow
- street names
- lot/block numbers and lot type
- plan number
- geodetic bench mark, etc.

2.03 All manholes, catchbasins, curbs, sidewalks, fencing, hydrants, utility pedestals, street lights, easements, turning circles and any other item which may impact the design and review of the grading, shall be shown.

2.04 Semi-detached lots shall be denoted SD, backsplits shall be denoted BS and walkouts shall be denoted by WO types.

2.05 Drawings shall also show:

- existing contours at 0.5m intervals (maximum), including beyond the subdivision limits, sufficient to determine existing drainage patterns.
- any watercourse running through or abutting the proposed development and identify the Regional storm water levels.
- location and cross section of the overland flow route/outlet for the 'major' storm.
- proposed centreline road elevations every 25 metres and all changes in vertical alignment.
- existing and proposed elevations at all lot corners and points of grade change.
- building envelopes with proposed front and rear elevations and direction of surface runoff.

LOT GRADING AND TREE PRESERVATION—30

- 2.06 Drawings shall denote all swales (except typical side yard swales), including alignment changes and key invert elevations. Also show all 3:1 slopes, retaining walls (including type, length, top/bottom of wall elevations) rear yard catchbasins (including rim and invert elevations and dimensions from property line).
- 2.07 Rural developments shall include a culvert schedule showing diameter, gauge, length and type.
- 2.08 Show all lots requiring 'engineered fill'.

3.0 INDIVIDUAL HOUSE SITING PLANS

- 3.01 Individual house sitings shall conform to the approved Master Grading Plan. Scale 1:250 Metric (216mm x 279mm legal size paper).

The plan must show all items noted on the Master Grading plan and any requirements from other departments or agencies, plus the following:

- 40M plan number and Lot number (in lower right corner)
 - locations of all services including inverts at property line of the sanitary and storm
 - house siting information (i.e. front, side and rear setbacks)
 - proposed grades around the house and detailed swale, slope and retaining wall information and elevations
 - percent slope of rear yard surface, swales and driveways
 - location, length and width of driveway
 - elevations of first floor of house, garage sill, top of basement slab and underside of footings
 - street furniture, catchbasins, fencing and any trees to be preserved
- 3.02 A Declaration must be signed and dated under the Consulting Engineer's seal, as follows:

"This proposal conforms with the Municipality's grading criteria and approved subdivision master lot grading plan and the proposed house type is compatible with the grading. The proposed driveway location does not conflict with adjacent driveways, walkways, catchbasin, hydrant, valve or any street utility."

LOT GRADING AND TREE PRESERVATION—31

4.0 LOT GRADING DESIGN

- 4.01 All drainage from developed lands shall be provided for internally. Drainage over abutting lands shall only be permitted in exceptional cases, with the landowner's written permission, at the discretion of the Director of Engineering Services. External drainage must be accommodated through subdivision lands. Where external grading forms part of any design, such written permission shall be included with the submission.
- 4.02 Storm water flows in excess of the design capacity of the piped storm sewer system shall be accommodated as overland flow within the roadway or defined swales to an approved point of acceptance. The overland storm flow route ("Major Storm") shall be calculated using rainfall intensity-duration curve for a hundred year return period or as otherwise approved by the Director of Engineering Services. Major flows shall not encroach onto private lands.
- 4.03 The lot grading design shall provide for the temporary drainage and erosion control of all blocks of land that are intended for future development. Such grading must accommodate the temporary conditions as well as the future design.
- 4.04 Grading along the subdivision limits shall be carefully controlled to prevent disturbance of adjoining property or any tree root systems. Proposed grades must meet all existing grades smoothly, with a sufficient buffer to ensure no future undermining or disturbance to existing property, fences or trees, etc.
- 4.05 The rear yards must be designed with surface grades between 2% and 5% at any location. A 3:1 slope shall be used to take up any additional grade difference, to a maximum of 1.5 m vertical. Otherwise the use of an approved dry stone retaining wall is required. In any case, the total grade differential of rear lot is not to exceed 15%.
- This shall be measured from the rear of the house to the top of retaining walls or inverts of swales (highest or lowest point of the rear yard) and from side lot line to side lot line. The measurement giving the steepest grade will govern.
- 4.06 All rear yards are to have a minimum usable depth of 6.0 m, exclusive of all embankments and rear drainage swales. (Definition of usable; surface grade of 5% maximum at any location)
- 4.07 The front yards of all residential lots shall be graded to drain towards the street.
- 4.08 Boulevards shall be graded with a consistent 2% slope from the property to the curb and all water boxes, manhole covers, valve boxes, etc. shall be set flush with the sod surface.
- 4.09 Front draining lots shall be designed with aprons extending a minimum of 4 metres from the rear of the house and to a minimum depth of 150 mm. Drainage shall be carried to the front via swales located as far from the house as possible.

LOT GRADING AND TREE PRESERVATION—32

- 4.10 Sod shall be at 150mm below the brickline.
- 4.11 Every effort shall be made to direct roof water leader discharge to the front.
- 4.12 When distance between dwellings is 1.8m or less, 19mm clear stone may be used.
- 4.13 Sheet flows from one lot shall not enter onto another lot unless confined to swales. Intercepting swales are to be constructed on the higher side of the common lot line and shall confine flows into the lower property's side yard swales.
- 4.14 Swales shall have a maximum length of 60 metres and shall range in depth from 150mm to 500mm. Swales shall be "V" shaped with 3:1 side slopes and shall be located directly adjacent to the lot line on the higher side, where space reasonably permits. The maximum distance from the property line to the centreline of any swale shall be 1.5 m.
- 4.15 The maximum contributing area for sideyard swales or rear yard swales draining onto roadways shall be the lesser of: 4 rear yards or 400 sq. metres. The maximum contributing area for rear yard catchbasins shall be the lesser of: 10 rear yards or 1000 sq. metres.
- 4.16 Driveways shall not be used as outlets for any swales. At adjacent driveways, a shallow swale or depression between the driveways is encouraged to prevent "sheet flow" on the driveways. All driveways shall have positive drainage toward the roadway.
- 4.17 Driveway grades shall be designed between 2% and 6%. Due to the imprecise nature of house construction, actual as-built grades may vary from the approved design. However, when requested, the Consulting Engineer must certify that the driveway has consistent positive drainage to the street and that it does not exceed a grade of 10%.
- 4.18 All driveways are to have a minimum clearance of 1.0 m to any above ground utility (i.e.: utility poles, transformers, pedestals, 1.5m at hydrants, etc.) Driveways shall not cross over or blend into adjacent driveways and shall be designed straight to roadway without curves or bends. Provide a minimum 0.3m full curb between driveways.
- 4.19 Rear yard catchbasins and outlet pipes shall be located entirely on one lot. In general, outlet pipes for rear yard catchbasins shall be located 0.5 m from the lot line while the centreline of the catchbasin shall be located 0.75 m from both lot lines. 1.5 m easements are required on each side of the lot line for rear lot catchbasin leads.
- 4.20 All retaining walls are to be approved, dry-stone interlocking, with no tiebacks:
- timber retaining walls are not permitted. (Except for internal cosmetic terracing)
 - retaining walls shall not exceed 1.5 m in height
 - slopes and retaining walls are to be constructed on the lower property, directly adjacent to property lines.

LOT GRADING AND TREE PRESERVATION—33

- retaining walls 0.75m or higher require 1.5m chainlink fence, extending to the nearest property line. Such retaining walls shall be Durahold or equivalent, to accommodate fencing.
- construction details of all retaining walls must be shown on the approved Engineering Drawings. The Developer's Consulting engineer shall be responsible for the design, location and inspection during construction and certification of all retaining walls.

5.0 CERTIFICATION

- 5.01 In accordance with the provisions of the subdivision agreement, the Developer's engineer shall certify, in a form acceptable to the Director, that each lot has been reviewed and conforms with the Municipality's grading criteria and the approved grading and house siting plans. (see format at end of this section). Detailed field survey information must be provided if requested, for any lot. All certifications must be dated and signed by a professional civil engineer. Certifications cannot be accepted during the winter and spring months.
- 5.02 No variance from the criteria or plans will be permitted, except where approved by the Director. The Director's decision will be based on the extent and impact of the variance on the lot, and on the specific circumstances.
- 5.03 The certification of any lot shall not relieve the Developer/builder of the responsibility to correct substandard grading or significant settlements, to the satisfaction of the Director.

6.0 TREE PRESERVATION PLAN

- 6.01 In conjunction with the Grading and Drainage Plan, and prior to the issuance of any Authorization to Commence works, the Owner shall obtain the written approval of the Director of Engineering of a plan for the preservation of suitable trees on the said Lands (the "Tree Preservation Plan"). Such plan shall include a reasonable inventory of all trees, and a summary of which trees are proposed to be removed or preserved, in accordance with the conditions set out below. The Director may designate certain areas to be exempt from the tree inventory requirements (right of ways, urban building envelopes and front yards) at his sole discretion.

In general, the Tree Preservation Plan shall itemize in detail:

- the location, species, health, ground elevation at base and approximate size of all existing trees over 30 cm in circumference (measured at 1.5m above the ground), and all existing hedges, ornamental or specimen trees and any unique or rare vegetation.

LOT GRADING AND TREE PRESERVATION—34

- a summary of all existing trees referred to in subparagraph (1) which are intended to be removed during the development of the Lands. Reasons for removal must be clarified, such as significant elevation differences between existing and proposed grades, conflicts with roadways, underground services or buildings or, individual tree species heartiness, life expectancy, tolerance to change in environment and aesthetics.
 - a summary of all existing trees referred to in subparagraph (1) which are intended to be preserved during the development of the said Lands, including their replacement value in accordance with guidelines set out by The International Society of Arboriculture (I.S.A.).
- 6.02 The Owner shall not, and shall not permit others, to remove or carry out any work which may remove, damage or destroy any tree or root system within or abutting the Lands, without prior written approval of the Tree Preservation Plan.
- 6.03 Prior to removing any trees, the Owner shall provide securities for replacement of trees designated to be preserved. The amount of such securities shall be determined at the sole discretion of the Director, based on the Tree Preservation Plan
- 6.04 Until all of the Works are accepted by the Municipality, the Owner shall reasonably ensure all trees which are designated to be preserved do not subsequently become injured, damaged, destroyed or weakened to a state of unrecoverable health, for any reason. Should this occur, upon written notice by the Director, the Owner shall plant replacement trees to the satisfaction of the Director, of equivalent value as set out in the Tree Preservation Plan. The location, size, species and value of any replacement tree shall be determined by the Director at his discretion.
- 6.05 Should the Owner be able to demonstrate, to the satisfaction of the Director, that any such tree loss occurred despite tree preservation efforts or due to conditions beyond the control of the Owner, the Director may elect to waive replacement requirements. However, the Director may request that the remains of such tree or trees be removed and the area restored with sod, and that such costs be fully borne by the Owner.
- 6.06 Until all of the Works are accepted by the Municipality, purchasers shall not be permitted to remove trees designated to be preserved, without the written approval of the Owner and the Director, for valid reasons.

LOT GRADING CERTIFICATE

This is to certify that we have inspected the lot grading for Lot __, Plan 40M- ____.

The lot has been graded to conform with the approved Lot Grading Plan, drawing No. _____, prepared by (Consulting Engineer's name) and the approved House Siting Plan.

The grading properly accommodates adjacent lands and where adjacent lands have not yet been sodded, we have verified that all grades, swales and slopes, etc. will properly accommodate future drainage and grading.

No drainage problems were apparent at the time of inspection and it is not expected that any drainage problems will occur in the future.

Signed/stamped by P.Eng.

Date

SECTION 900 INSPECTION, MATERIALS AND CONSTRUCTION—36

1.0 GENERAL

- 1.01 These guidelines are to be used in conjunction with the conditions set out in the Subdivision Agreement, in particular Schedule "I"—Duties of Owner's Engineer and Schedule "L"—Regulations for Construction.
- 1.02 The Owner's Consulting Engineer shall provide full-time inspection and supervision of all Works.
- 1.03 The Consulting Engineer shall take extensive preconstruction photos of surrounding lands, and shall provide dated/described copies of such photographs to the Municipality.
- 1.04 Construction sites are to be maintained to prevent unnecessary ponding of water.
- 1.05 Prior to requesting the inspections (or re-inspections) from the Municipality, the Consulting Engineer shall verify the proper completion of the Works, and submit a written request.
- 1.06 All equipment, materials and methods involved in trench backfill, filling, granulars, concrete and asphalt shall be monitored and Certified as acceptable by the owner's Geotechnical Engineer (see attached form). Unless noted otherwise, the term "compacted" shall mean 95% Standard Proctor or higher (native materials) and 98% Standard Proctor or higher (granular materials). Such certification shall be in a form acceptable to the Director and shall include all supporting documentation and test results. Mix designs for concrete and asphalt shall be obtained and approved by the Geotechnical Engineer. The Geotechnical Engineer shall ensure that the type, frequency, location and results of all tests is sufficient to ensure certification. Furthermore, the Geotechnical Engineer shall ensure all results for a given stage of construction are acceptable prior to commencing the next stage of construction.

2.0 STORM SEWERS

- 2.01 All materials shall be visually inspected by the Consulting Engineer upon delivery, to ensure conformity with specifications and the approved engineering drawings, and to ensure any damaged/substandard material is marked and removed from the site immediately.
- 2.02 Installation of storm sewers shall be continually monitored for adherence to proper bedding, pipe laying, backfilling and compaction procedures. All storm sewers, catchbasins and manholes shall be constructed true to line and grade. Street catchbasins are to be installed in precise alignment with curb lines, and no tolerances will be permitted. Rear yard catchbasins shall be accurately surveyed and verified by the Consulting Engineer for correct location prior to the issuance of a Certificate of Completion. The precast tops of manholes and catchbasins shall be checked for excess brickwork prior to roadbuilding.

INSPECTION, MATERIALS AND CONSTRUCTION—37

- 2.03 Trench widths shall be kept at a minimum, while providing proper widths to enable mechanical compaction. All trenching must adhere to Ministry of Labour requirements.
- 2.04 Manholes are to be backfilled with compacted sand, extending min. 1.0 m from the outside face of the structure. (Catchbasins min. 300mm from the face of the structure).
- 2.05 House connections shall extend 1.5 m into the lots and be plugged with approved removable plugs. Bedding shall be as per approved standard drawing. Tees shall be pre-manufactured for pipes 450mm diameter and smaller, cored (on site) if 525mm diameter or larger, and shall be secure and watertight. The invert of all tees shall be located above the springline of the sewer main and shall be a minimum of 600mm from the nearest adjacent tee or joint, unless approved otherwise.
- 2.06 Concrete pipes into/out of manholes shall be concrete cradled precisely to the first joint.
- 2.07 All storm sewers, including street and rear yard catchbasin leads (and individual service laterals where directed), shall be inspected using approved high quality video recording equipment and procedures. The inspection shall be carried out in a manner acceptable to the Municipality and all video tapes shall be submitted to the Municipality for review and permanent storage. Video re-inspections may also be requested.
- 2.08 Infiltration shall not be permitted into the storm sewer system. All leaks shall be investigated to determine their source and shall be corrected to the satisfaction of the Municipality.
- 2.09 Pipes which have failed in any manner, including cracking (0.3mm design loading cracks excepted), exposed reinforcing or other defects, shall be removed and replaced to the satisfaction of the Director. No repairs shall be undertaken without the consent and the direct supervision of the Municipality.

3.0 BACKFILLING, GRADING AND GRANULAR ROAD BASE

- 3.01 Backfill containing organic or frozen material, or excessively moist material which cannot support conventional compaction equipment, shall be deemed unsuitable and shall not be used. The initial lift of native backfill shall not exceed 1.0 m in depth above the compacted sand cover over the storm sewer and each additional lift shall be placed in layers not exceeding 300mm loose measurement (unless pre-authorized by the Geotechnical Engineer). Each lift shall be compacted until it has achieved the specified density before any additional lifts are placed.
- 3.02 Backfilling operations shall follow pipe installation as closely as possible and be limited to 75 metres of open trench maximum.

INSPECTION, MATERIALS AND CONSTRUCTION—38

- 3.03 The Geotechnical Engineer shall document all tests, including failures and retests, in sequential order, continuously throughout the project. A copy of all test results shall be kept at the site trailer, in addition to providing daily plotting of all test results on the plan and profile drawings.
- 3.04 The Consulting Engineer shall ensure that the subgrade is fine graded to the correct width, and that the minimum 3% crossfall is consistently maintained, with no longitudinal ruts permitted. The Geotechnical Engineer shall employ appropriate testing measures to assess the suitability of the subgrade, including proof-rolling, and shall make appropriate recommendations to the Consulting Engineer and Municipality. Whenever possible, localized soft areas in the subgrade shall be replaced with suitable native material, not granular material. When additional granulars must be used, they should be considered on a street by street basis. Subdrains must then be lowered accordingly, and 10:1 frost tapers must be provided.
- 3.05 Subdrains shall be installed only after the subgrade has been proof-rolled and the road structure has been finalized. Subdrains shall be installed true to line and grade, in a trench condition, and shall be backfilled with approved granular material having aggregates not exceeding 19mm. All subdrains shall be supplied with a filter sock.
- 3.06 The Geotechnical Engineer shall confirm (in a form acceptable to the Municipality) the acceptability of each stage of roadbuilding prior to subsequent stages commencing. Subsequent stages of road construction shall not proceed without approval from Municipal staff.
- 3.07 After base curbs are installed, all Granular B must be regraded and verified by Municipal staff prior to placing Granular A. (Any Granular A placed prior to base curbs shall be considered Granular B).
- 3.08 Granular material shall be tested in accordance with the latest O.P.S.S. specifications. Material shall be tested at the pit and also as it arrives on site. Material not conforming to the specifications shall be rejected and removed from site.

4.0 CONCRETE WORKS

- 4.01 Concrete to be supplied by M.T.O. approved sources only. All concrete shall be monitored and all applicable tests (compressive strength, slump, air entrainment, etc.) shall be carried out by the Geotechnical Engineer as specified in accordance with the applicable OPSS and ASTM specifications. Any material not meeting specifications shall be rejected immediately.
- 4.02 All concrete to be placed as per the Municipality's Standard Drawings. Contraction joints shall be in accordance with the Municipality's standard drawings and shall be completed as early as practical and before any initial cracking occurs. Large cracks or several

INSPECTION, MATERIALS AND CONSTRUCTION—39

smaller cracks between contraction joints in curbs will require removal and replacement of that section of curb. Sidewalks with distinct cracks will also require replacement.

- 4.03 Curing compound shall be generously applied to all exposed concrete surfaces within 2 hours of finishing (within 1 hour on hot or windy days). Where freezing overnight temperatures are anticipated, the application of curing compound may be postponed only in lieu of insulated blankets or other approved methods. The type and duration of such insulation shall be approved by the Municipality and upon removal, curing compound shall then be immediately applied as directed.
- 4.04 All curbs to be placed using approved curb machines. Excess concrete formed during curb machine placement shall be promptly trimmed and removed prior to setting. The minimum length of curb to be removed and replaced shall be 1.5 m. No concrete patch repairs shall be permitted.
- 4.05 Prior to placement of top curb, base curb shall be cleaned and then inspected by Municipal staff. Base curb and stirrups shall be repaired and/or replaced as directed.
- 4.06 The depth of top curb at the edge of pavement shall not be less than 100mm and shall be continually verified by the Consulting Engineer.
- 4.07 Immediately prior to the placement of top curb or sidewalk, the existing surface shall be dampened with water to prevent leaching of moisture from the fresh concrete.
- 4.08 Driveways to be as per approved house siting plans, with minimum widths of 4.6m for single detached homes.
- 4.09 Where top curb or full curb is placed, surface asphalt must also be placed within the same calendar year to prevent damage to the front edge of curb. If this cannot be achieved, an asphalt fillet is to be neatly placed abutting the front edge of the curbs, the method and details of which shall be to the approval of municipal field staff.

5.0 ASPHALT PAVEMENT

- 5.01 All asphalt pavement materials shall be supplied by MTO approved sources, in accordance with OPSS 310, 1003 and 1150 (latest revisions thereof). Marshall/extraction/density tests shall be carried out by the Geotechnical Engineer in accordance with OPSS and relating to the approved mix design. Note: Provincial and Municipal projects differ with respect to contract administration, paving project sizes, Quality Control/Quality Assurance procedures and testing frequencies. As such, several OPSS specifications are not appropriate for Municipal use and shall not apply, as determined in the sole discretion of the Director.

Since current testing methods do not enable ongoing monitoring (and therefore corrective action) of the asphalt, the onus shall be on the asphalt suppliers and contractors to ensure,

INSPECTION, MATERIALS AND CONSTRUCTION—40

their product fully conforms to the specifications with no allowance for 'Borderline' test results permitted. Those results will be deemed 'Unacceptable'. Results falling within the Rejectable range shall generally require asphalt removal. Results falling within the Unacceptable range may also require removal, depending on the extent of the problem, traffic volumes and field workmanship. The Director may elect to allow certain Unacceptable asphalt to remain, provided sufficient financial compensation is made to compensate for potential reduction in service life. The option of compensation, and the amount, shall be at the sole discretion of the Director. Should all parties not come to an agreement on the compensation amount, the asphalt is to be removed and replaced.

- 5.02 Prior to placing surface asphalt, base asphalt shall be swept clean of all dirt, debris and dust. Areas of base asphalt shall be removed and replaced as directed, using a vertical sawcut at all perimeters. The use of a Geo-Grid or approved equivalent may also be directed by the Municipality. Low areas shall be padded to ensure a surface mat of uniform thickness.
- 5.03 Each manhole is to be precisely raised to final grade, and verified by the Developer's Consulting Engineer and Municipal staff.
- 5.04 Tack coat shall be applied just prior to surface paving operations and shall be allowed to dry until it is in a proper condition of tackiness. The length of roadway prepared shall be limited to the immediate paving section, to reduce tracking. It shall be evenly applied at the rate of 0.4 litres/sq. m taking care not to spray curbs, sidewalks or any other adjacent surfaces.
- 5.05 Driveway paving shall be fully inspected and verified for depths of stone and asphalt, and the compaction thereof, and ensuring that asphalt is at a sufficient temperature for placement. HL3A (HL3F) will not be permitted, except in special cases with the approval of the Director. Crowning or rounding of the limestone will not be permitted. Materials testing may be required for driveway apron gravel and asphalt, as directed.

6.0 TOPSOIL, SODDING AND SEEDING

- 6.01 All areas requiring sod shall first be neatly prepared for 150mm depth of topsoil. This preparation depth must be verified by the Consulting Engineer prior to placement of any topsoil. After approval by the consultant, 150mm topsoil shall then be placed and levelled. The consultant shall then complete a final inspection for topsoil grade and the removal of any larger stones, branches or other improper material, prior to any sod being laid. Any topsoil or sod placed without prior verification and approval from the consultant shall be deemed unacceptable. Topsoil and sodding shall meet the requirements of OPSS 570 and 571, in addition to meeting any additional requirements set out in these specifications. Boulevards shall have 2% positive drainage toward the curb and shall be fully sodded, except in areas covered by driveway aprons or sidewalk.
- 6.02 All topsoil shall be free from native till or clay, roots, vegetation, weeds or debris, stones

INSPECTION, MATERIALS AND CONSTRUCTION—41

and clods over 50mm in diameter. Imported topsoil, if required, shall be fertile, loamy, screened material of a quality acceptable to the Director (containing approximately 4% organic matter for clay loams and 2% minimum organic matter for sandy loams with acidity range of 6.0 PH). Topsoil infested by the seeds of noxious weeds will not be acceptable.

- 6.03 All sod shall meet the requirements of Ontario Sod Grower's Association No. 1 Bluegrass Fescue Nursery sod. The sod shall be taken from good loamy soil and shall be healthy, well permeated with roots, have uniform texture and appearance and be free from weeds. Sod must be laid within thirty-six (36) hours of being cut. Care must be taken during its transportation and placement to prevent any drying out. Sod shall match flush with all adjacent surfaces and shall have no open gaps, overlapping edges or uneven joints. Where adjacent or fronting lands have already been sodded, care must be taken to ensure drainage is maintained and a smooth transition is achieved. On slopes 3:1 and steeper, sod shall be staked as required.
- 6.04 Laid sod shall be immediately rolled to produce an even surface and watering shall commence immediately thereafter and shall continue on a regular basis until healthy roots are well established and permanent. If sod fails to establish immediately, it shall be removed and replaced. No attempt shall be made to try to re-establish weak/dead sod through continual watering, unless specific permission is granted by the Director. The entire work shall be done in a thoroughly workmanlike manner with an even surface, and professional in appearance. Any sod deemed unfit by the Director shall be immediately removed from site and replaced. In this regard, it is in the best interest of the contractor to communicate with residents regarding the needs of newly laid sod over the first year.
- 6.05 Where approved by the Municipality, hydraulic seeding and mulching may be performed provided that it conforms to the Ontario Provincial Standard Specification No. 572.

CERTIFICATION OF MATERIALS TESTING

Project:

This letter is to confirm that (*geotechnical engineer*) has carried out geotechnical monitoring on the above noted project, under the general direction of (*Consulting Engineer*). Since sampling and testing of materials is representative in nature and since monitoring of procedures is periodic in nature, this certification cannot ensure the uniformity of results for the overall project.

We hereby certify that:

1. We have carried out sampling and testing of materials and reviewed compaction equipment and procedures for the above noted project, including trench backfill, road granulars, concrete and asphalt works, and that such monitoring was carried out by qualified personnel from our firm.
2. Although such monitoring was periodic in nature, sufficient quantity and distribution of samples and tests were performed to enable us to provide a reasonable assessment of the project as a whole, and to make geotechnical recommendations where necessary.
3. Test results not meeting minimum requirements are noted in the attached summary. The Municipality of Clarington has been advised of these results and has approved the remedial action to be taken.
4. Based on the frequency, distribution and results of such sampling, monitoring and testing, we advise that the results (with the exception of any that may be referred to under Note 3) are in compliance with Municipal standards and good engineering practices.

Signed/stamped by P.Eng.

Date

Municipality of Clarington

Index to Standard Drawings

SEWERS

C-101	1200mm Precast Concrete Maintenance Hole
C-102	1500-3000mm Precast Concrete Maintenance Hole
C-104	Single Catch Basin
C-105	Double Catch Basin
C-106	Sump Pump Detail
C-108	Storm Sewer Trench Bedding Detail
C-109	PVC Street Catch Basin Connection
C-110	House Service Connection Locations
C-111	Storm Sewer Service Connections
C-112	Square Maintenance Hole Frame with Cover
C-113	Self Leveling Maintenance Hole Assembly
C-114	Beehive Catch Basin Frame and Cover
C-115	Rear Yard Catch Basin Detail
C-116	Catch Basin Inlet Control Device

ROAD DESIGN

C-201	15m R.O.W. – Service Road
C-202	18m R.O.W. – Urban
C-203	8.5m R.O.W. – Laneway
C-204	20m R.O.W. – Urban with LID
C-205	23m R.O.W. – Urban
C-206	26m R.O.W. – Urban
C-207	30m R.O.W. – Urban
C-208	36m R.O.W. – Urban
C-209	20m R.O.W. – 6.7m Pavement
C-211	Cul-de-sac – Urban
C-212	Cul-de-sac – Rural

ROAD CONSTRUCTION

C-301	Perforated Plastic Subdrains
C-302	Standard Curb & Gutter
C-304	Standard Two Stage Curb & Gutter
C-305	Curb & Gutter Detail at Catch Basin
C-307	Standard Concrete Sidewalk
C-308	Concrete Walkway
C-309	Urban Residential Driveway Apron
C-310	Temporary Turning Circle
C-311	Surface Pavement Joint Treatment
C-312	Multi-Use Path
C-313	Joint-Use Trench
C-314	Commercial Entrance
C-315	Asphalt Restoration Area

MISCELLANEOUS ROAD WORKS

C-401	Street Termination Detail (non-asphalt)
C-401B	Street Termination Detail (asphalt)
C-402	Street Sign Detail
C-402B	Specialized Street Sign Detail
C-404	P-Gate Detail

FENCING & PLANTING DETAILS

C-501	1.8m/1.5m/1.2m Black Vinyl Chain Link Fence
C-501B	1.8m/1.5m/1.2m Galvanized Steel Chain Link Fence
C-502	Black Vinyl Chain Link Single Gate
C-502B	Galvanized Steel Chain Link Single Gate
C-503	Black Vinyl Chain Link Double Gate
C-503B	Galvanized Steel Chain Link Double Gate
C-505	Acoustic Fencing Details
C-506	Acoustic Fencing Details (Open Space/Railways)
C-508	Planting Detail (Deciduous)
C-509	Planting Detail (Coniferous)

LOT GRADING DETAILS

C-801	Front Drainage Lot
C-802	Split Drainage Lot
C-803	Walk-out/Backsplit Drainage Lot
C-804	Rural/Estate Front Drainage Lot
C-805	Rural/Estate Split Drainage Lot

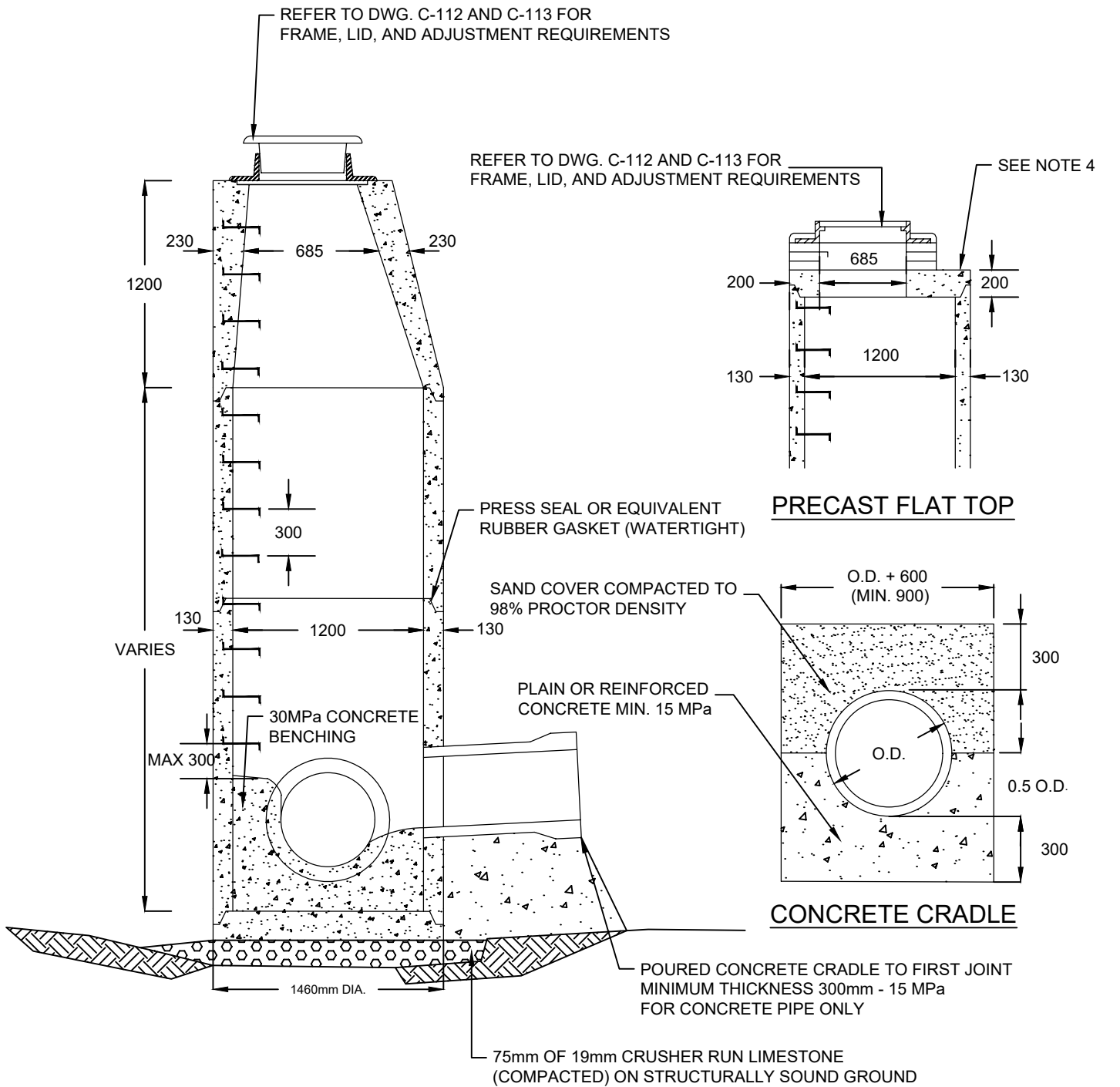

NOTES

1. ALL PRECAST COMPONENTS TO BE FROM APPROVED SUPPLIERS.
2. PIPES MUST NOT ENTER AT A MAINTENANCE HOLE SECTION JOINT.
3. ALUMINUM MAINTENANCE HOLE STEPS AS PER OPSD 405.020.
4. PRECAST FLAT TOP DESIGN ONLY AS APPROVED.
5. SAFETY GRATES ARE REQUIRED FOR MAINTENANCE HOLE DEPTHS GREATER THAN 5.0m. MAXIMUM SPACING BETWEEN SAFETY GRATES IS 4.5m.
6. MAINTENANCE HOLES TO BE INDIVIDUALLY DESIGNED AND APPROVED WHEN MANHOLE DEPTHS ARE GREATER THAN 7.5m
7. FOR MAINTENANCE HOLE SIZING SEE OPSD 701.021 (USE PIPE Ø + 100mm FOR MAXIMUM HOLE SIZE).
8. COMPACTED SAND BACKFILL WITHIN 1.0m OF MAINTENANCE HOLE.
9. SEMI-CAST MAINTENANCE HOLES TO BE INDIVIDUALLY DESIGNED AND APPROVED.
10. WRAP OUTSIDE OF BRICKWORK SURFACES ENTIRELY WITH WATERPROOF MEMBRANE SO THAT IT OVERLAPS TOP OF PRECAST AND FRAME.

ALL DIMENSIONS ARE IN MILLIMETRES UNLESS OTHERWISE NOTED

	<h2 style="margin: 0;">1200mm PRECAST CONCRETE MAINTENANCE HOLE</h2>	REVISION NO.: 2
		REVISION DATE: DECEMBER 2025
		C-101

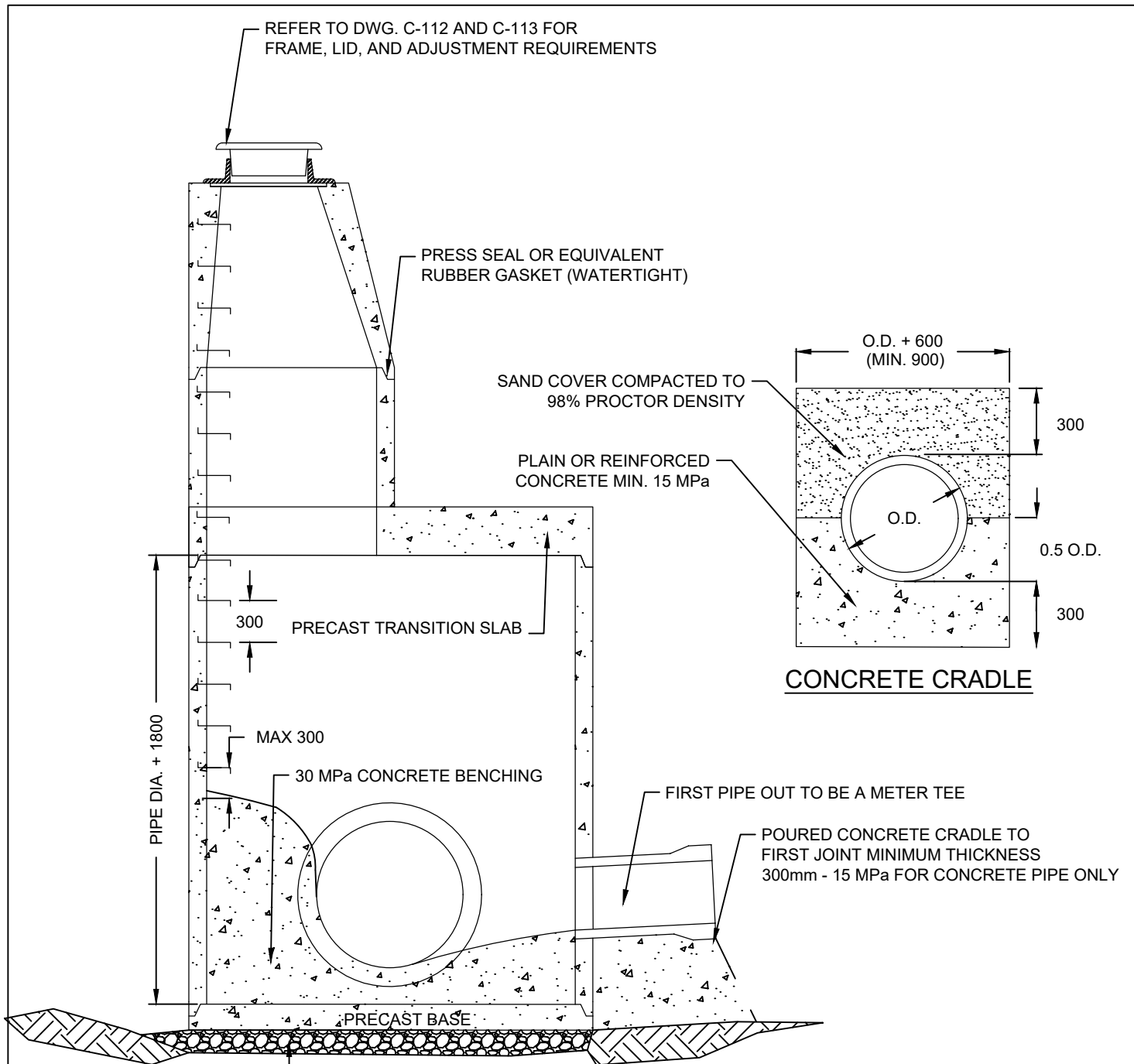

NOTES

1. ALL PRECAST COMPONENTS TO BE FROM APPROVED SUPPLIERS.
2. PIPES MUST NOT ENTER AT A MAINTENANCE HOLE SECTION JOINT.
3. ALUMINUM MAINTENANCE HOLE STEPS AS PER OPSD 405.020.
4. PRECAST FLAT TOP DESIGN ONLY AS APPROVED.
5. SAFETY GRATES ARE REQUIRED FOR MAINTENANCE HOLE DEPTHS GREATER THAN 5.0m. MAXIMUM SPACING BETWEEN SAFETY GRATES IS 4.5m.
6. MAINTENANCE HOLES TO BE INDIVIDUALLY DESIGNED AND APPROVED WHEN MAINTENANCE HOLE DEPTHS ARE GREATER THAN 7.5m
7. FOR MAINTENANCE HOLE SIZING SEE OPSD 701.021 (USE PIPE Ø + 100mm FOR MAXIMUM HOLE SIZE).
8. COMPACTED SAND BACKFILL WITHIN 1.0m OF MAINTENANCE HOLE.
9. SEMI-CAST MAINTENANCE HOLES TO BE INDIVIDUALLY DESIGNED AND APPROVED.
10. WRAP OUTSIDE OF BRICKWORK SURFACES ENTIRELY WITH WATERPROOF MEMBRANE SO THAT IT OVERLAPS TOP OF PRECAST AND FRAME.

ALL DIMENSIONS ARE IN MILLIMETRES UNLESS OTHERWISE NOTED



**1500mm - 3000mm
PRECAST CONCRETE
MAINTENANCE HOLE**

REVISION NO.: 2
REVISION DATE: DECEMBER 2025

C-102

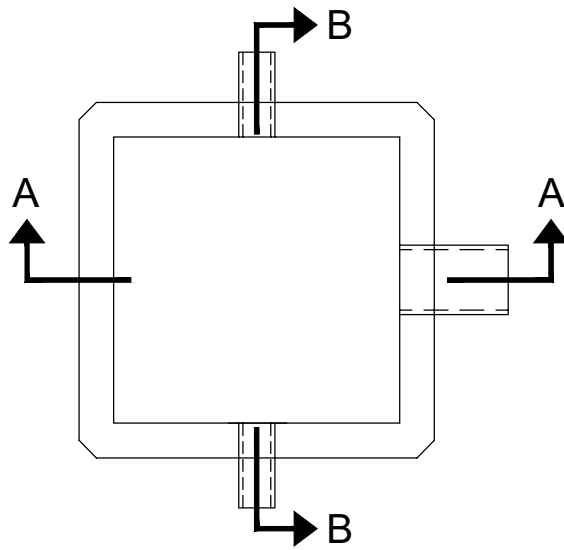

PLAN VIEW

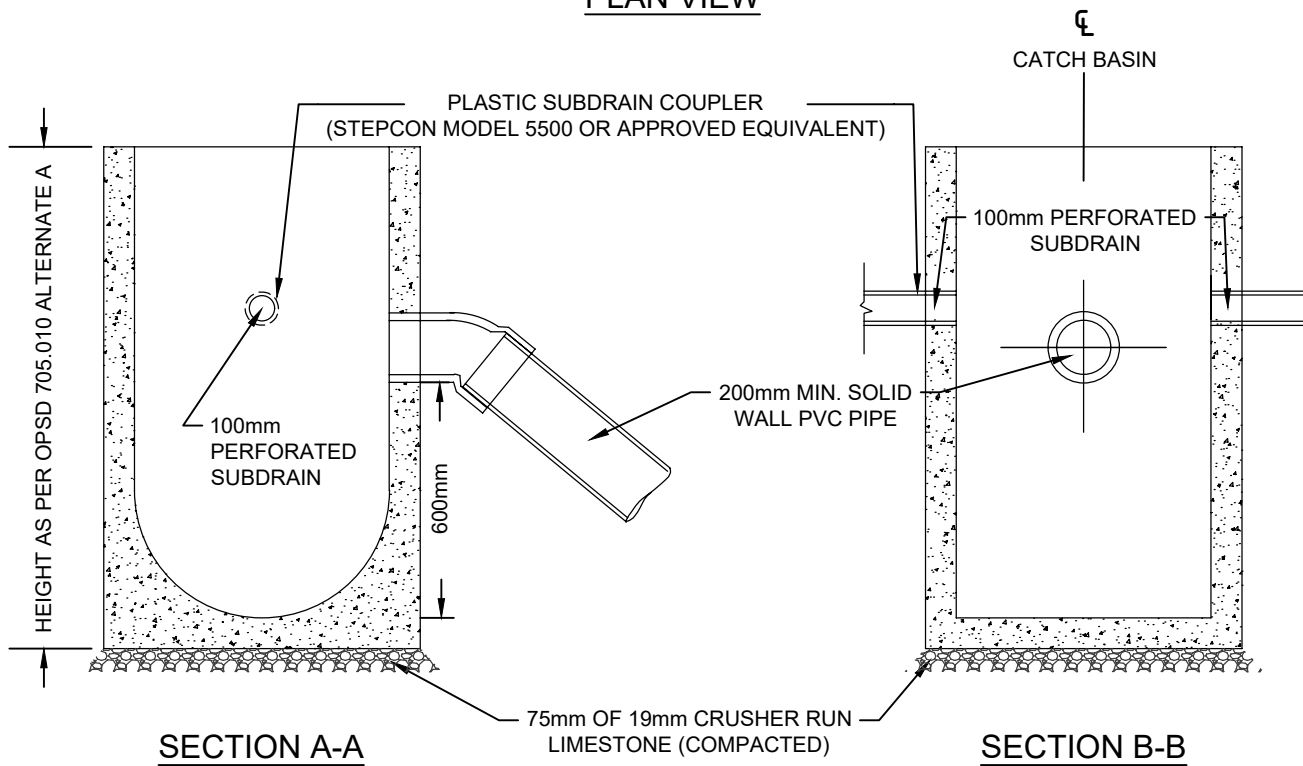

SECTION A-A

SECTION B-B

NOTES

1. PRECAST CONCRETE CATCH BASIN AS PER OPSD 705.010 AND OPSS 1351.
2. ALL PRECAST COMPONENTS TO BE FROM APPROVED SUPPLIERS.
3. COMPACTED SAND BACKFILL WITHIN 0.3m OF CATCH BASIN.
4. REFER TO DRAWING C-109 AND C-305 FOR ADDITIONAL DETAILS.
5. INVERT OF SUBDRAIN TO BE LEVEL OR ABOVE OBVERT OF CATCH BASIN LEAD.
6. LIFT HOLES TO BE COMPLETELY FILLED WITH MORTAR BEFORE BACKFILLING.
7. SUBDRAIN PIPE SHALL BE CONNECTED TO THE CATCH BASIN STRUCTURE USING PLASTIC SUBDRAIN COUPLERS (STEPCON MODEL 5500 OR APPROVED EQUIVALENT).
8. WRAP OUTSIDE OF BRICKWORK SURFACES ENTIRELY WITH WATERPROOF MEMBRANE SO THAT IT OVERLAPS TOP OF PRECAST AND FRAME.

ALL DIMENSIONS ARE IN MILLIMETRES UNLESS OTHERWISE NOTED

REVISION NO.: 3
REVISION DATE: DECEMBER 2025



SINGLE CATCH BASIN

C-104

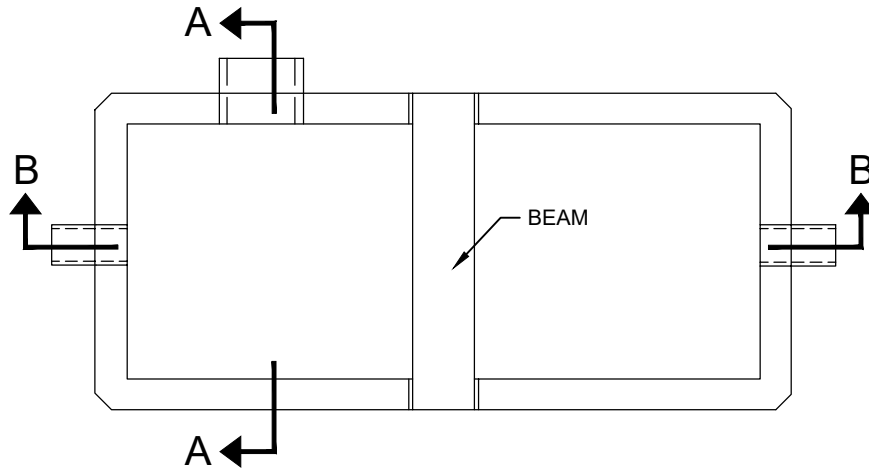

PLAN VIEW

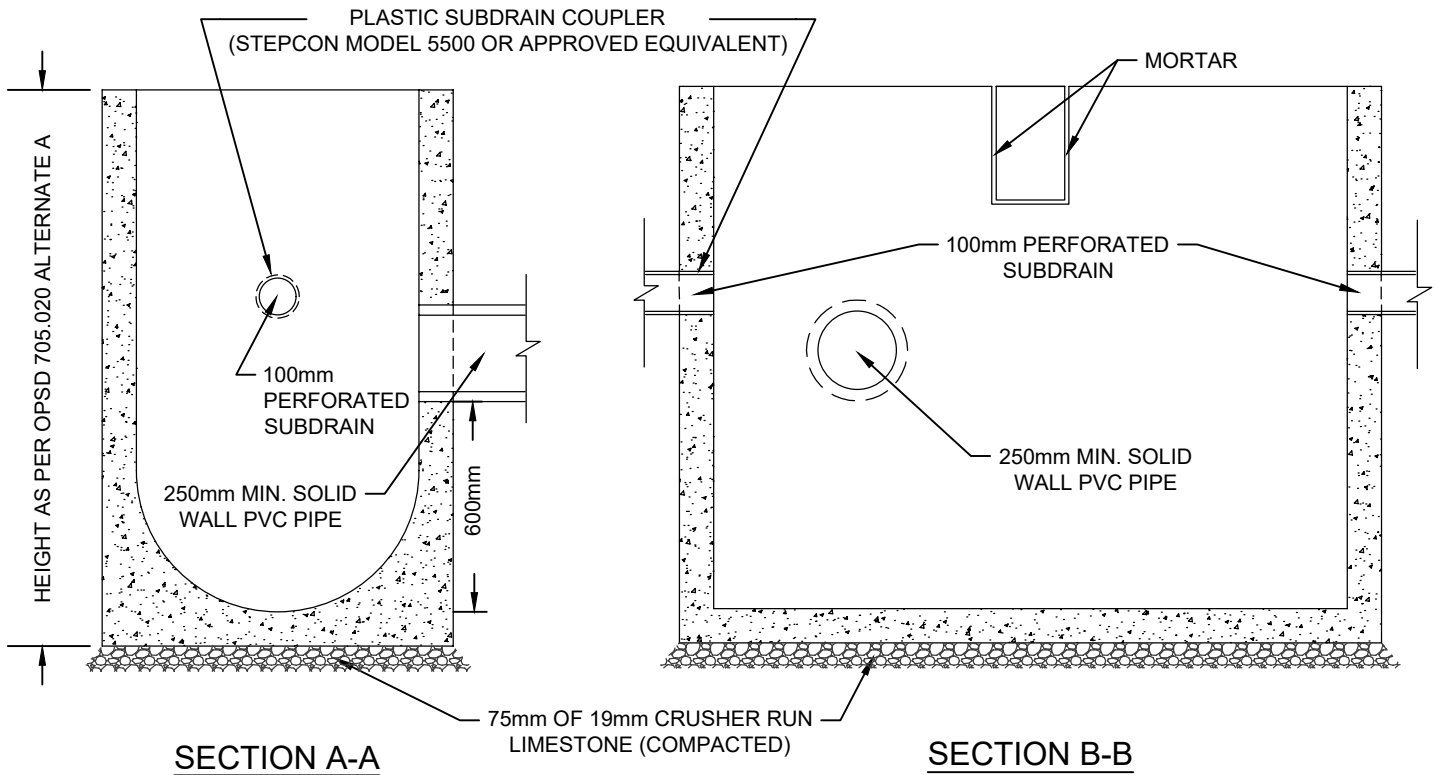

SECTION A-A

SECTION B-B

NOTES

1. PRECAST CONCRETE TWIN INLET CATCH BASIN AS PER OPSD 705.020 AND OPSS 1351.
2. ALL PRECAST COMPONENTS TO BE FROM APPROVED SUPPLIERS.
3. COMPACTED SAND BACKFILL WITHIN 0.3m OF CATCH BASIN.
4. REFER TO DRAWING C-109 AND C-305 FOR ADDITIONAL DETAILS.
5. INVERT OF SUBDRAIN TO BE LEVEL OR ABOVE OVERT OF CATCH BASIN LEAD.
6. LIFT HOLES TO BE COMPLETELY FILLED WITH MORTAR BEFORE BACKFILLING.
7. SUBDRAIN PIPE SHALL BE CONNECTED TO THE CATCH BASIN STRUCTURE USING PLASTIC SUBDRAIN COUPLERS (STEPCON MODEL 5500 OR APPROVED EQUIVALENT).
8. WRAP OUTSIDE OF BRICKWORK SURFACES ENTIRELY WITH WATERPROOF MEMBRANE SO THAT IT OVERLAPS TOP OF PRECAST AND FRAME.

ALL DIMENSIONS ARE IN MILLIMETRES UNLESS OTHERWISE NOTED

REVISION NO.: 3
REVISION DATE: DECEMBER 2025

Clarington

DOUBLE CATCH BASIN

C-105

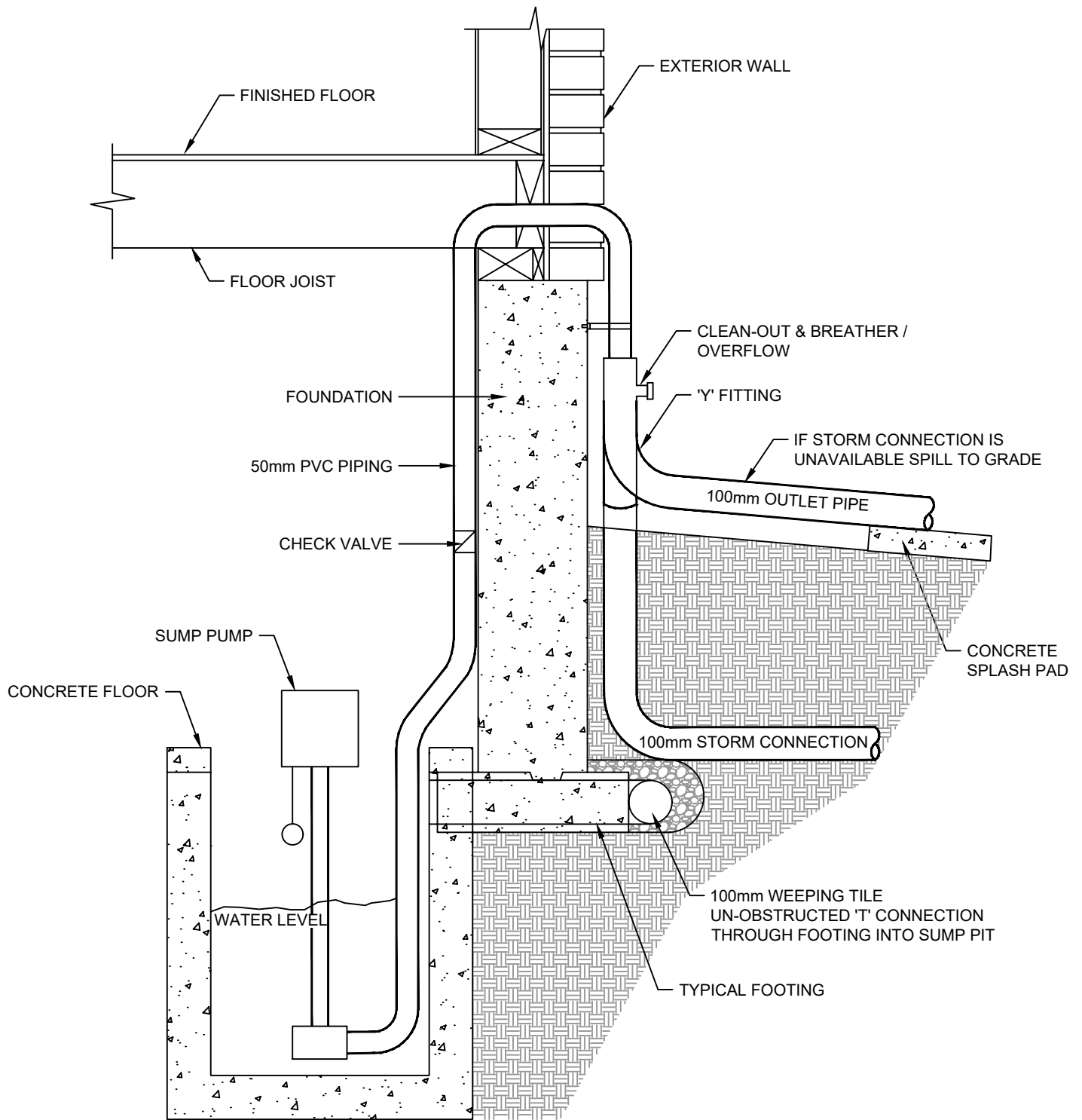

NOTES

1. ALL SUMP PUMP DISCHARGE PIPES REQUIRE A PERMIT THROUGH THE MUNICIPALITY'S BUILDING DIVISION.
2. PLUMBER TO REMOVE CAP AND INSTALL 100mm LINE-CLEAN-OUT AND CONNECT TO SUMP PUMP.
3. ALL WORKS ARE TO BE INSPECTED AND APPROVED BY BUILDING DIVISION OFFICIALS.

ALL DIMENSIONS ARE IN MILLIMETRES UNLESS OTHERWISE NOTED

REVISION NO.: 1
 REVISION DATE: DECEMBER 2025



**SUMP PUMP WITH / WITHOUT
 STORM DRAIN CONNECTION**

C-106

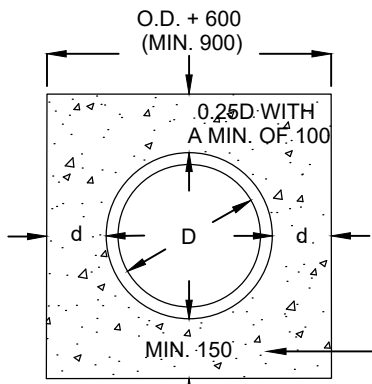

CONCRETE ENCASEMENT DETAIL

SAND COVER COMPACTED TO 98% PROCTOR DENSITY

PLAIN OR REINFORCED CONCRETE MIN. 10 MPa

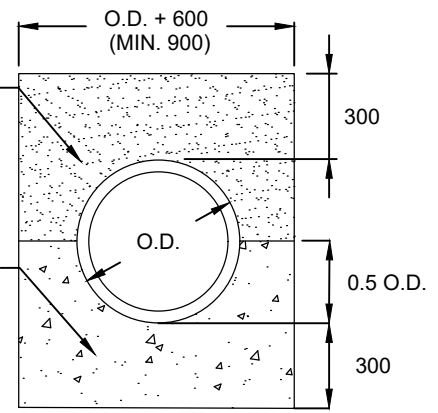

CONCRETE CRADLE

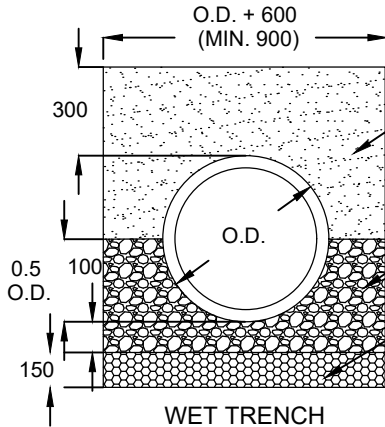

WET TRENCH

SAND COVER COMPACTED TO 98% PROCTOR DENSITY

19mm CRUSHER LIMESTONE COMPACTED TO 98% PROCTOR DENSITY

19mm TYPE 1 CLEAR STONE WRAPPED IN GEOTEXTILE (TERRAFIX 270R OR APPROVED EQUIVALENT)

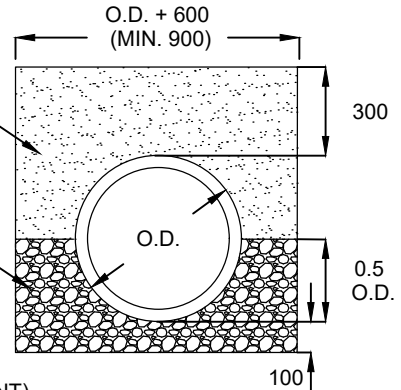

DRY TRENCH

CLASS B BEDDING

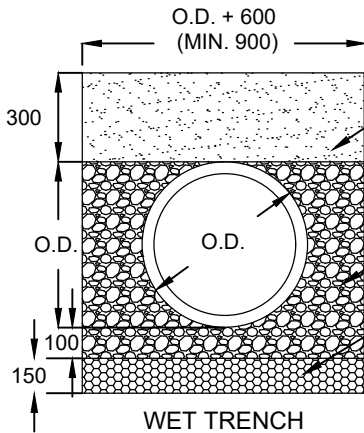

WET TRENCH

SAND COVER COMPACTED TO 98% PROCTOR DENSITY

19mm CRUSHER LIMESTONE COMPACTED TO 98% PROCTOR DENSITY

19mm TYPE 1 CLEAR STONE WRAPPED IN GEOTEXTILE (TERRAFIX 270R OR APPROVED EQUIVALENT)

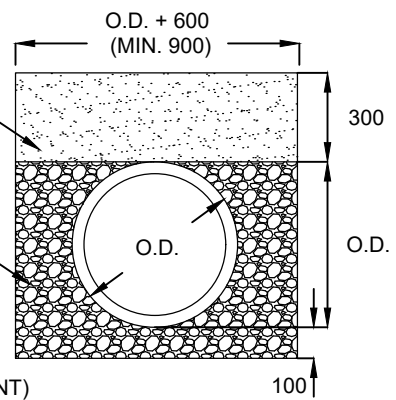

DRY TRENCH

CLASS P BEDDING

NOTES

1. CONCRETE SHALL CONFORM TO OPSS 1350.
2. BEDDING MATERIALS SHALL BE FULLY EXTENDED AND COMPACTED AGAINST TRENCH WALLS. BEDDING MATERIALS SHALL BE PLACED AND COMPACTED IN 150mm LAYERS.
3. NO MECHANICAL COMPACTION EQUIPMENT SHALL BE USED ON TOP OF PIPE PRIOR TO PLACING A MINIMUM OF 300mm OF COVER MATERIAL.
4. PIPE SHALL BE BEDDED TO PROPOSED LINE AND GRADE WITH A UNIFORM AND CONTINUOUS SUPPORT FROM BEDDING. BLOCKING WITH ANY HARD OBJECT IS NOT PERMITTED TO BRING THE PIPE TO GRADE.
5. 19mm DIAMETER CRUSHER RUN LIMESTONE SHALL CONFORM TO OPSS 1010 - GRANULAR A SPECIFICATIONS - TABLE 2.
6. 19mm TYPE 1 CLEAR STONE SHALL CONFORM TO OPSS 1004.

ALL DIMENSIONS ARE IN MILLIMETRES UNLESS OTHERWISE NOTED



STORM SEWER TRENCH BEDDING

REVISION NO.: 1
REVISION DATE: DECEMBER 2025

C-108

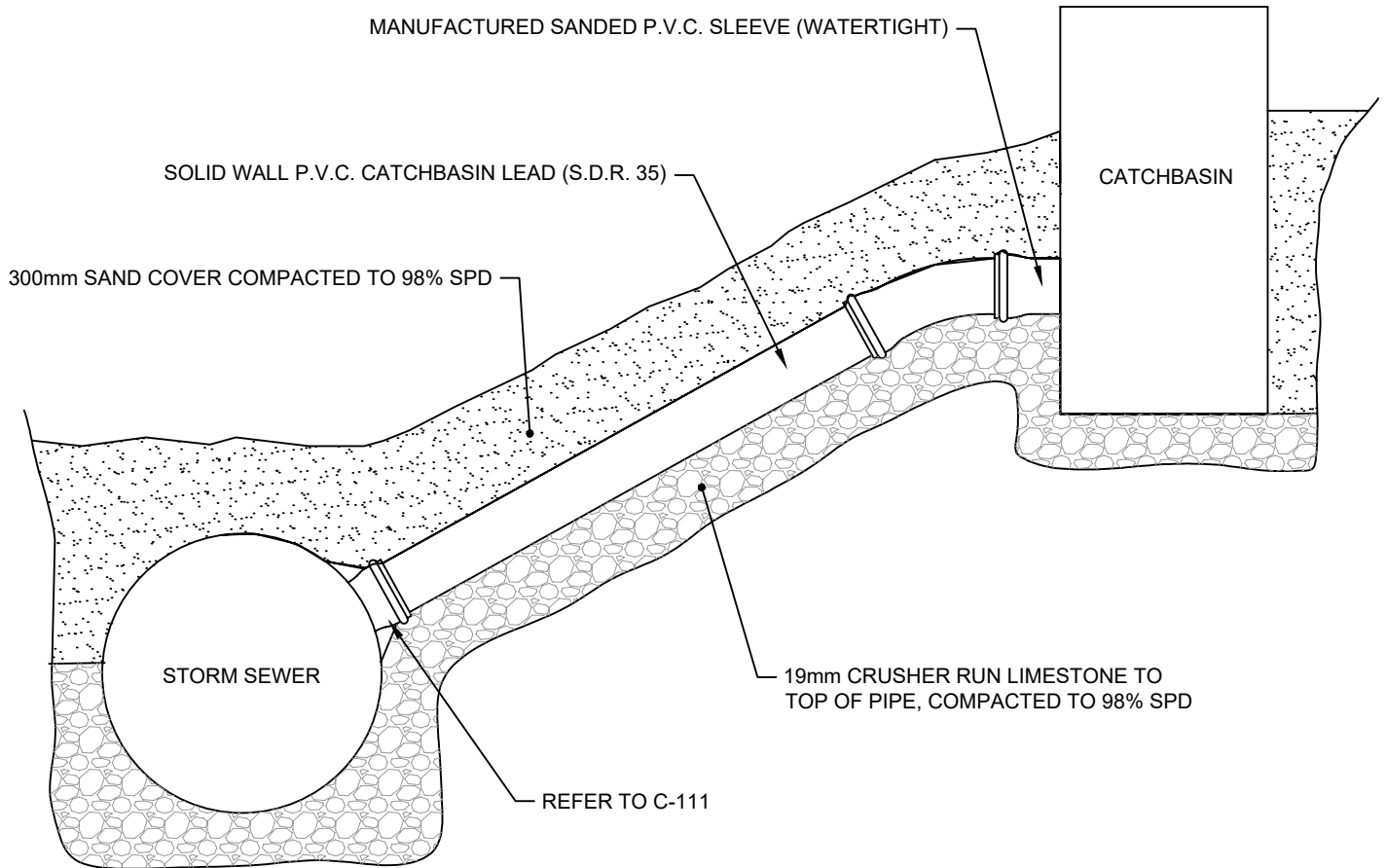

NOTES

1. PIPE TO ENTER CATCH BASIN AT RIGHT ANGLE.
2. 250mm Ø LEAD FOR DOUBLE CATCH BASINS.
3. 200mm Ø LEAD FOR SINGLE CATCH BASINS.
4. REFER TO DWG. C-108 FOR BEDDING DETAILS.

ALL DIMENSIONS ARE IN MILLIMETRES UNLESS OTHERWISE NOTED



P.V.C. STREET CATCH BASIN CONNECTION

REVISION NO.: 1
REVISION DATE: DECEMBER 2025

C-109

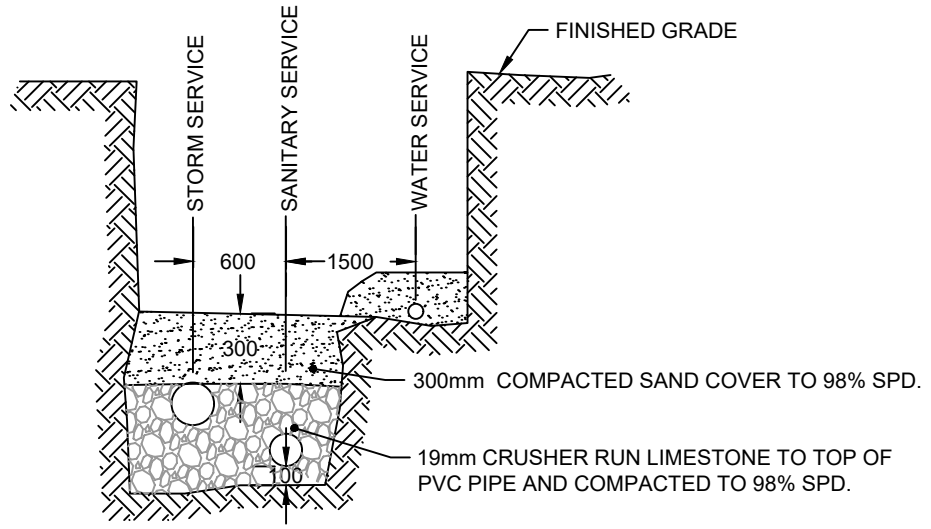
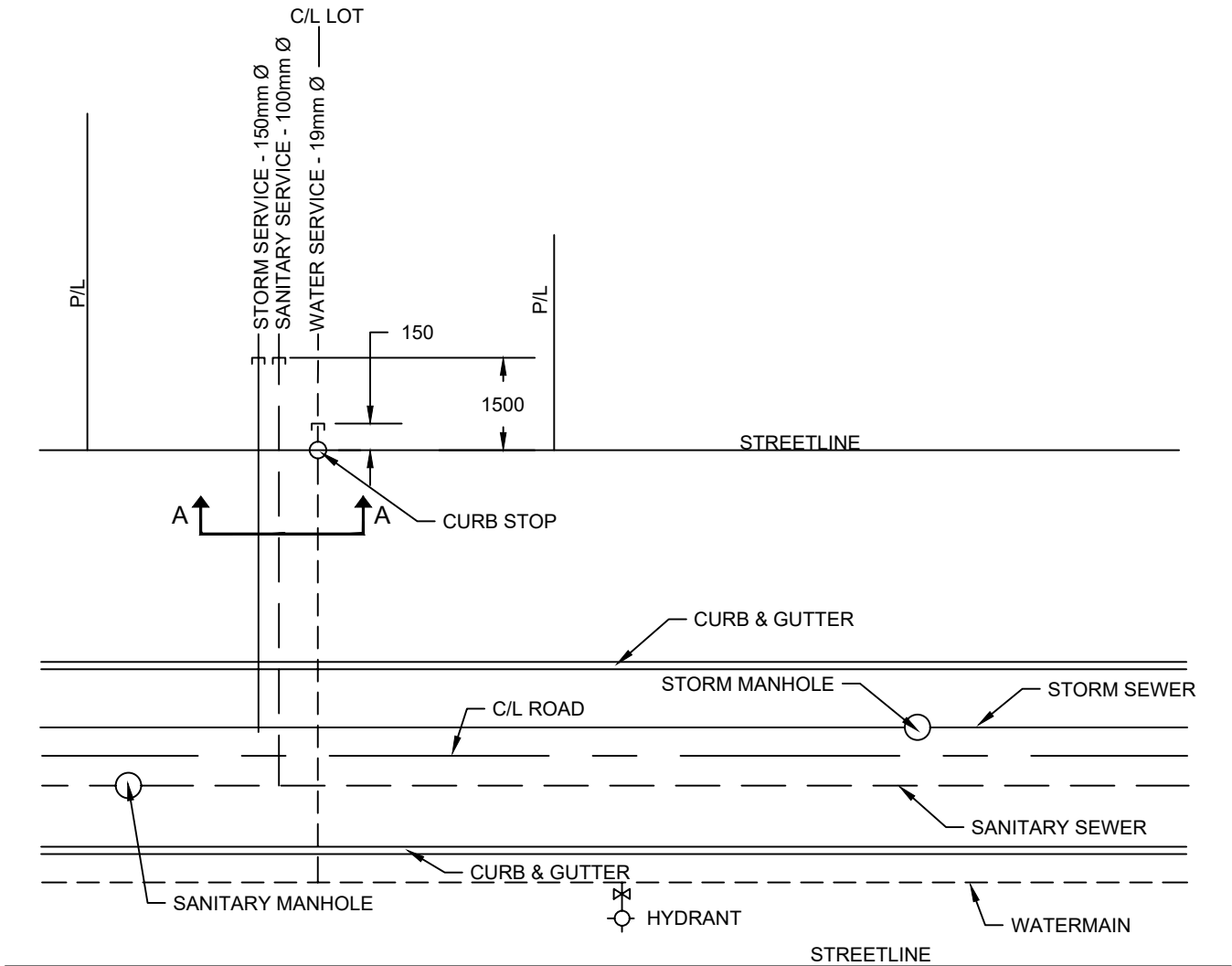

SECTION A-A
N.T.S.

NOTES

1. FOR STORM SERVICE CONNECTION DETAILS REFER TO C-111.
2. FOR SANITARY / WATER SERVICE CONNECTION DETAILS REFER TO REGION OF DURHAM SPECIFICATIONS.
3. REFER TO DWG. C-108 FOR BEDDING DETAILS.

ALL DIMENSIONS ARE IN MILLIMETRES UNLESS OTHERWISE NOTED



**HOUSE SERVICE
CONNECTION LOCATIONS**

REVISION NO.: 1
REVISION DATE: DECEMBER 2025

C-110

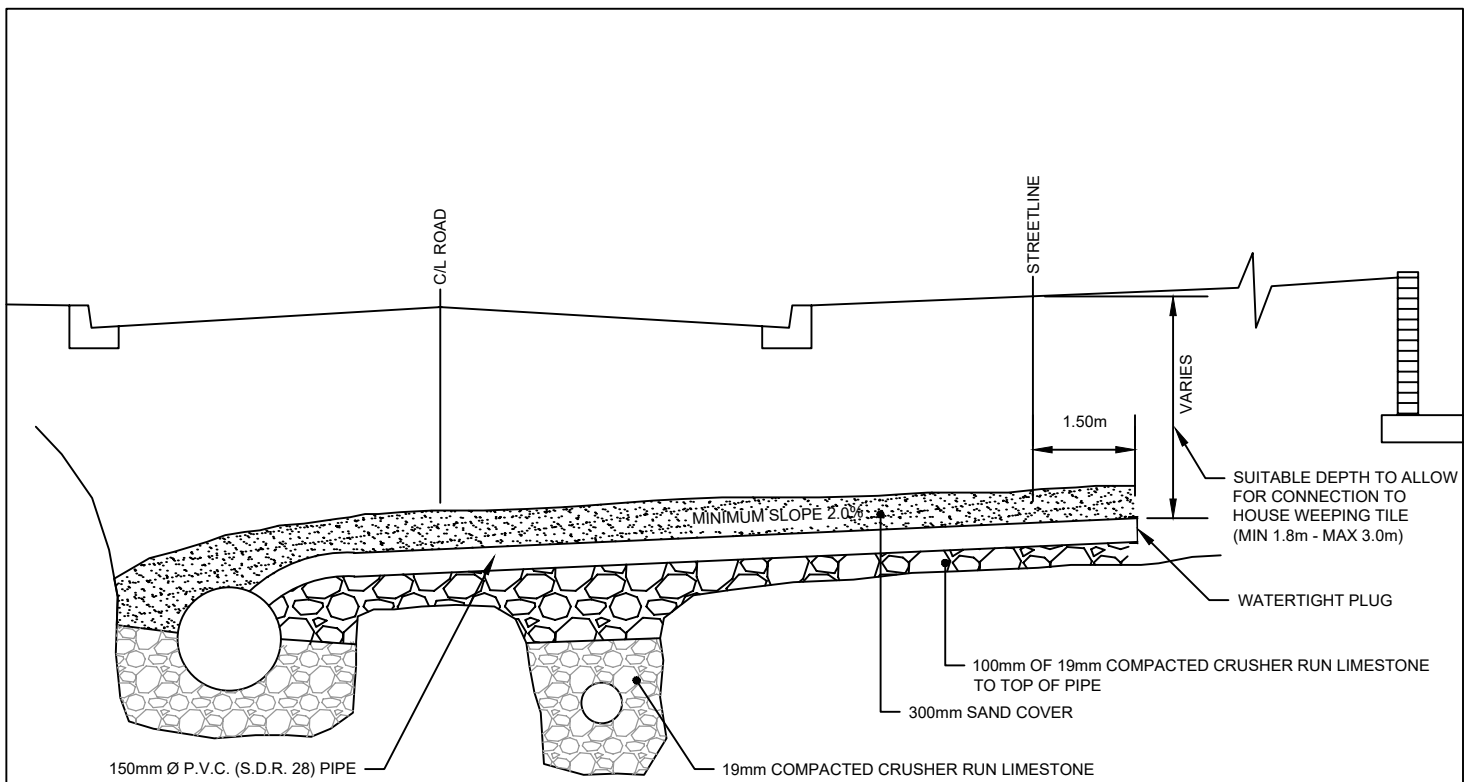

PROFILE

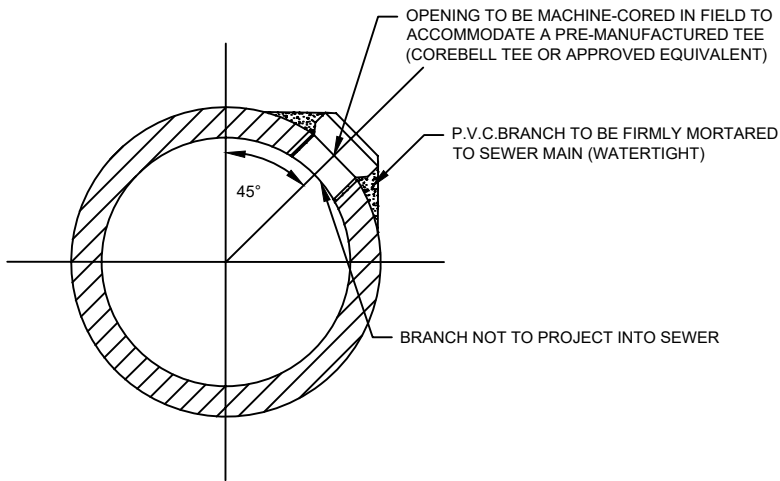

**CONNECTION FOR SEWER MAINS
525mm Ø & LARGER**

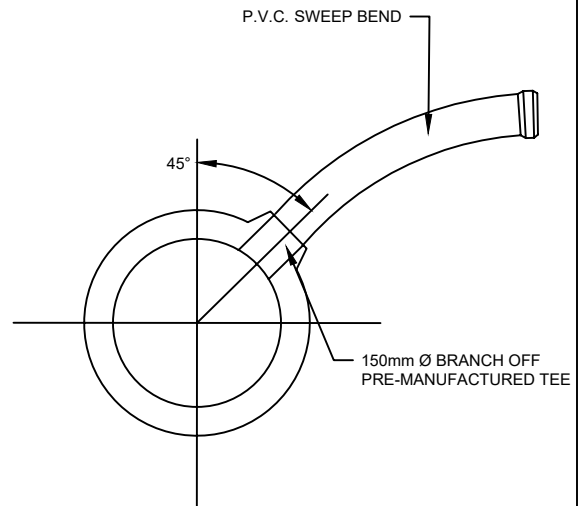

**CONNECTION FOR SEWER MAINS
450mm Ø & SMALLER**

NOTES

1. SERVICE CONNECTION INVERT TO ENTER SEWER MAIN AT SPRINGLINE OR HIGHER.
2. ALL PIPE CORES AND CONNECTIONS TO BE APPROVED BY THE MUNICIPALITY OF CLARINGTON.
3. REFER TO DWG C-108 FOR BEDDING DETAILS.

ALL DIMENSIONS ARE IN MILLIMETRES UNLESS OTHERWISE NOTED



**STORM SEWER
SERVICE CONNECTIONS**

REVISION NO.: 1
REVISION DATE: DECEMBER 2025

C-111

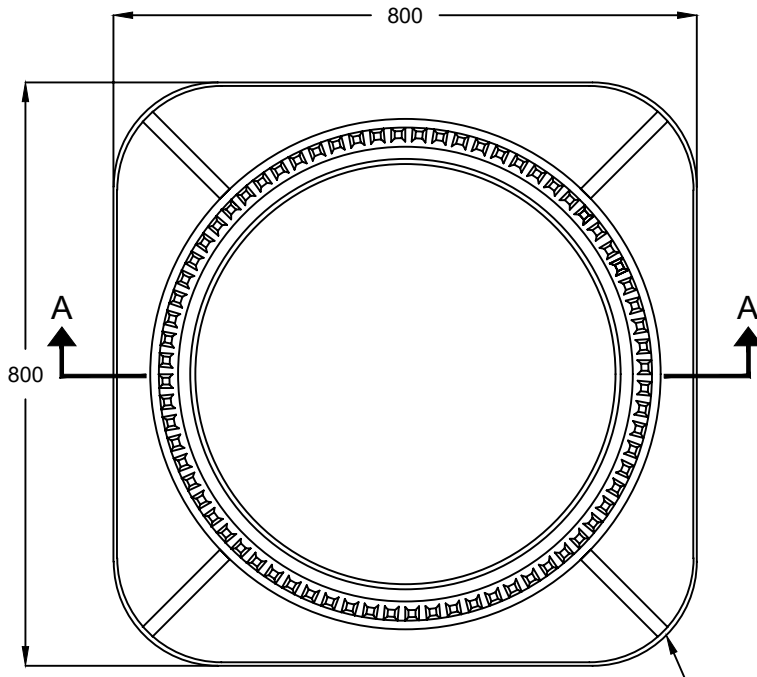

FRAME PLAN

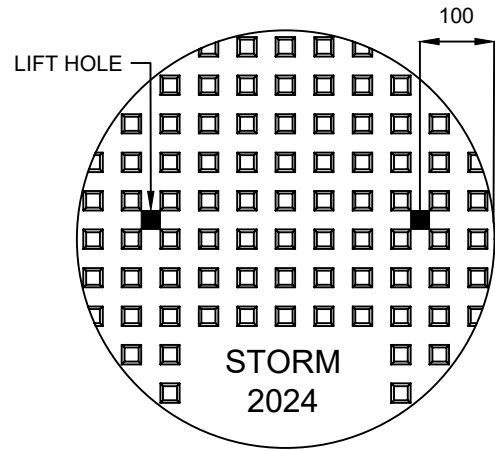

COVER PLAN

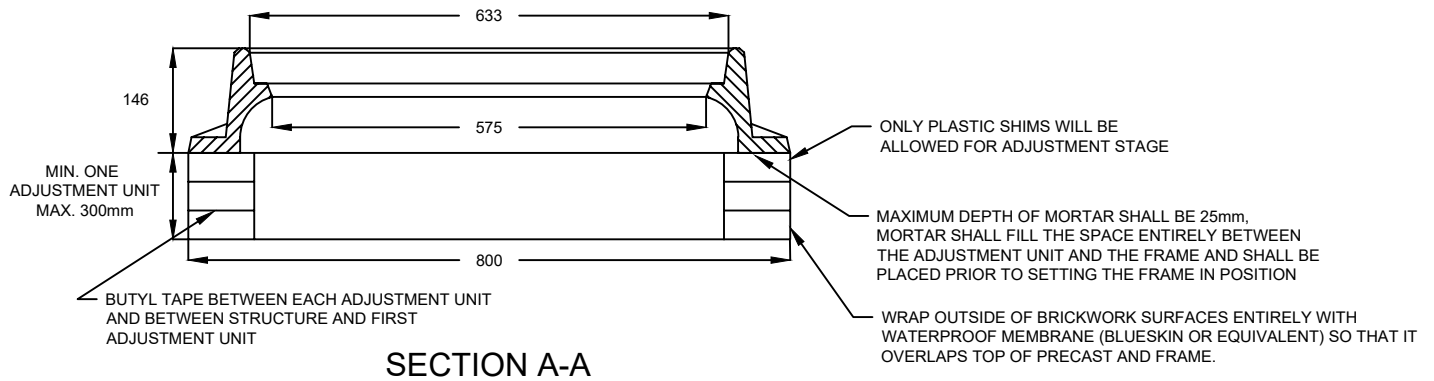

SECTION A-A

NOTES

1. ALL FRAMES AND GRATES TO BE APPROVED BY MUNICIPAL STAFF PRIOR TO INSTALLATION.
2. FRAME TO CONFORM TO OPSD 401.010.
3. COVER TO CONFORM TO OPSD 401.010 TYPE A.
4. THE DESIGNATION 'STORM' AND 'YEAR' ON CONSTRUCTION ARE TO BE DISTINCTLY CAST IN RAISED LETTERS AS SHOWN
5. MORTAR SHALL BE BAGGED PRE-MIXED SPEEDCRETE, OR APPROVED EQUIVALENT.
6. NAME OF MANUFACTURER IS TO BE DISTINCTLY CAST IN RAISED LETTERS.

ALL DIMENSIONS ARE IN MILLIMETRES UNLESS OTHERWISE NOTED



**SQUARE MAINTENANCE HOLE
FRAME WITH COVER**

REVISION NO.: 1
REVISION DATE: DECEMBER 2025

C-112

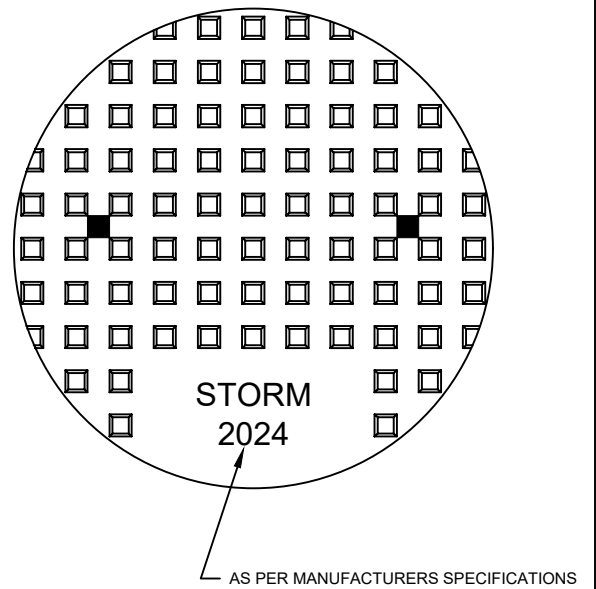
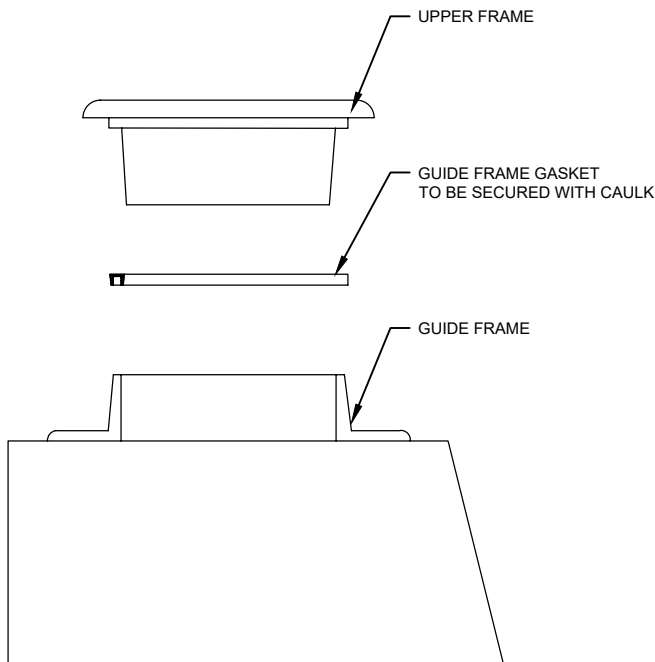
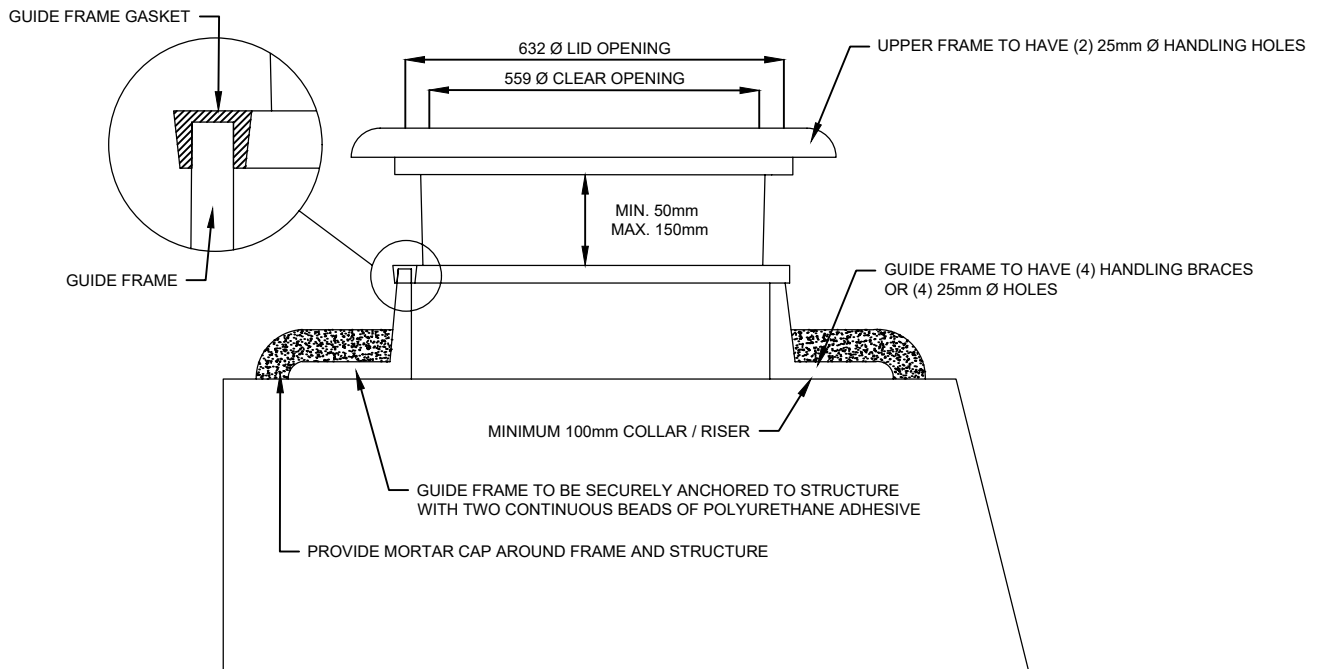

NOTES

1. ALL FRAMES AND GRATES TO BE APPROVED BY MUNICIPAL STAFF PRIOR TO INSTALLATION.
2. NAME OF MANUFACTURER IS TO BE DISTINCTLY CAST IN RAISED LETTERS.
3. THE DESIGNATION 'STORM' AND 'YEAR' OF CONSTRUCTION ARE TO BE DISTINCTLY CAST IN RAISED LETTERS AS SHOWN.

ALL DIMENSIONS ARE IN MILLIMETRES UNLESS OTHERWISE NOTED

REVISION NO.: 1
 REVISION DATE: DECEMBER 2025



**SELF LEVELING
 MAINTENANCE HOLE ASSEMBLY**

C-113

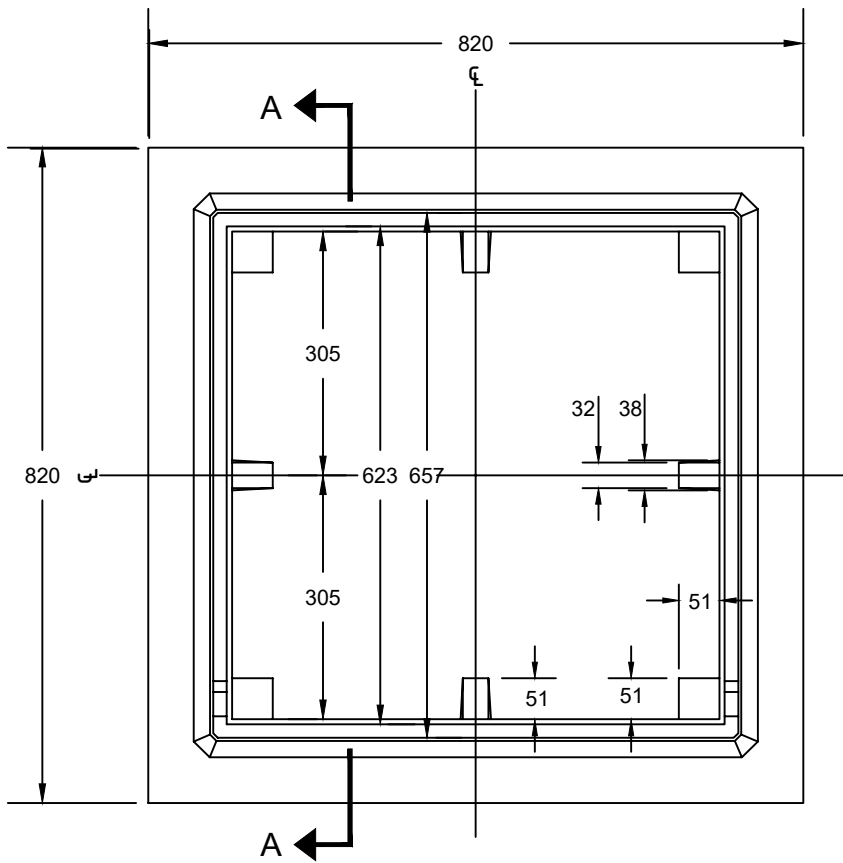

FRAME PLAN

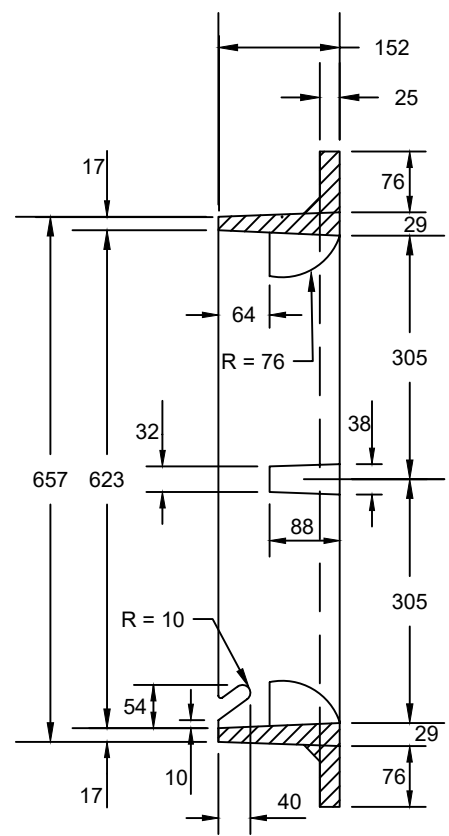

SECTION A-A

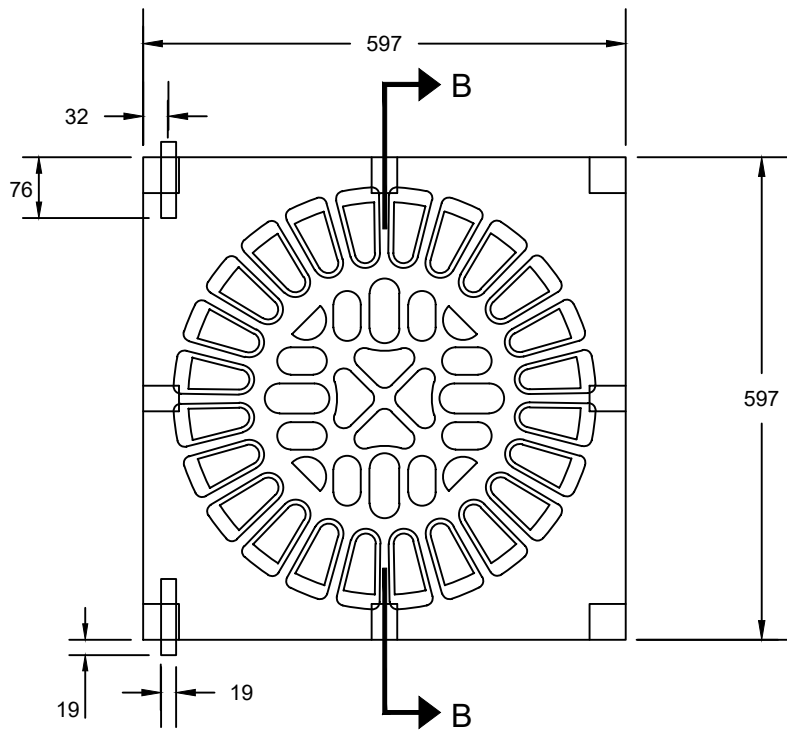

GRATE PLAN

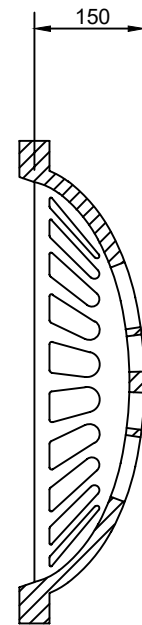

SECTION B-B

ALL DIMENSIONS ARE IN MILLIMETRES UNLESS OTHERWISE NOTED

REVISION NO.: 1
REVISION DATE: DECEMBER 2025



**BEEHIVE CATCH BASIN
FRAME & COVER**

C-114

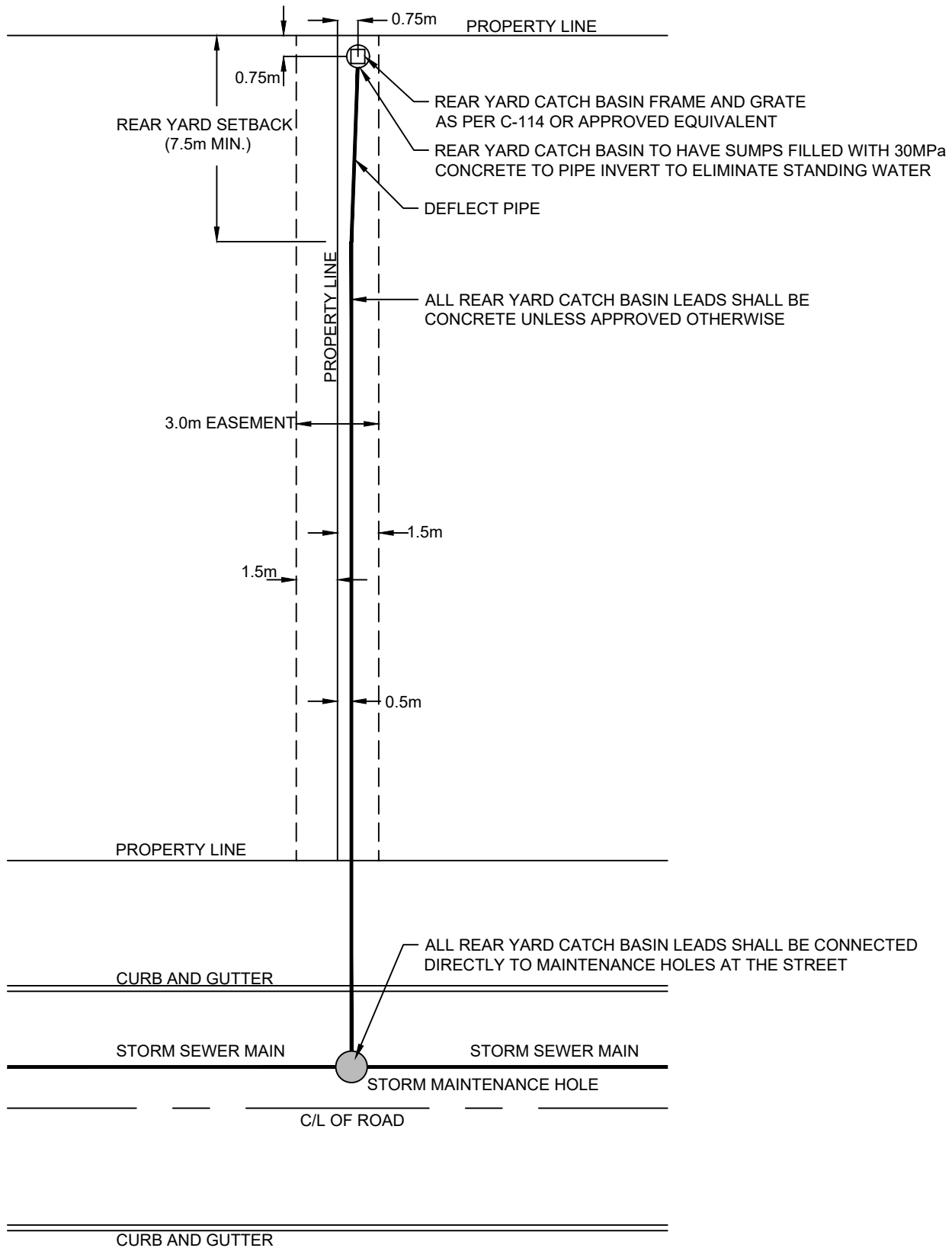

ALL DIMENSIONS ARE IN METRES UNLESS OTHERWISE NOTED



REAR YARD CATCH BASIN DETAIL

REVISION NO.: 1

REVISION DATE: DECEMBER 2025

C-115

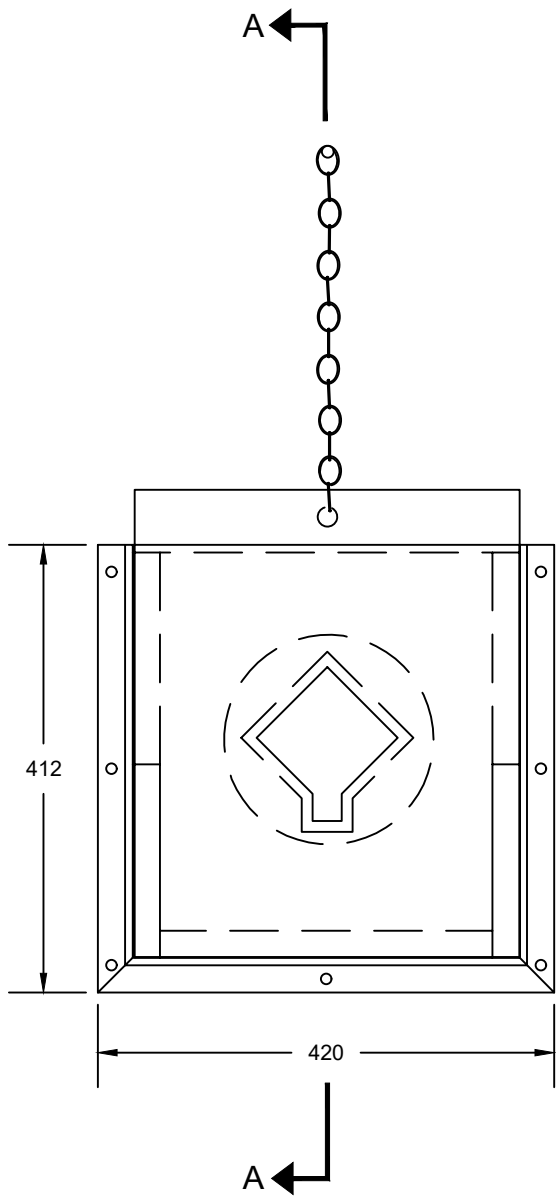

FRAME AND PLATE ELEVATION

#3 STRAIGHT LINK CHAIN (GALVANIZED)

SHACKLE

SECTION A-A

50

NOTES

1. SCEPTER OR APPROVED EQUIVALENT.
2. ALL ANGLES, BARS AND PLATE TO BE PVC MATERIAL.
3. HARDWARE SECURED WITH APPROVED 50mm GALVANIZED LAG BOLTS.
4. ALL PVC JOINTS TO BE SOLVENT WELDED,
5. CENTRE OF OPENING AT CENTRE OF OUTLET.
6. SIZE OF OPENING AS PER DESIGN.
7. ALL HARDWARE TO BE GALVANIZED.

ALL DIMENSIONS ARE IN MILLIMETRES UNLESS OTHERWISE NOTED

Clarington

**CATCH BASIN INLET
CONTROL DEVICE**

REVISION NO.: 1

REVISION DATE: DECEMBER 2025

C-116

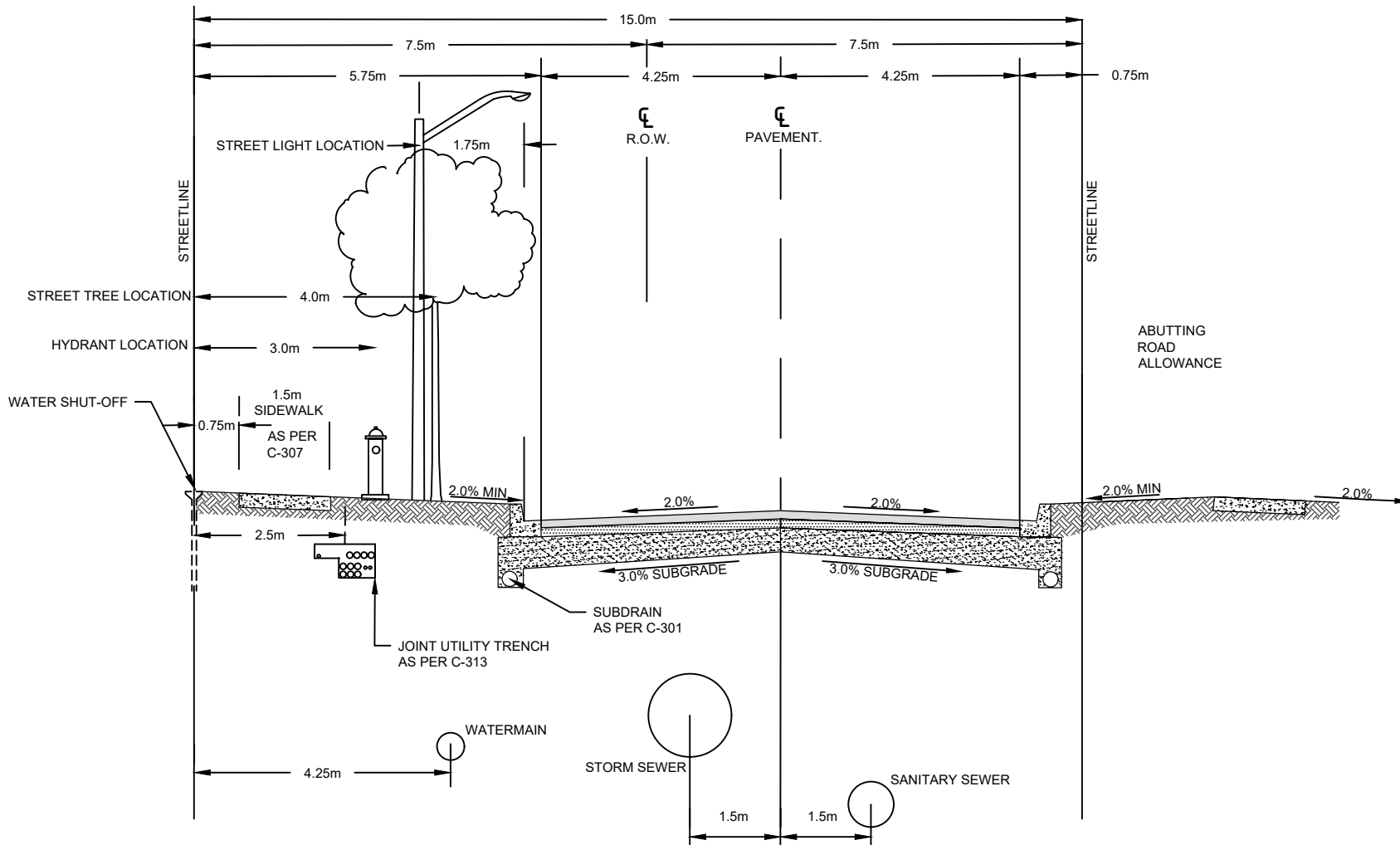

MINIMUM PAVEMENT DESIGN CRITERIA				
ROAD CLASS	SURFACE COURSE ASPHALT (HL3)	BASE COURSE ASPHALT (HL8)	GRANULAR 'A'	GRANULAR 'B' TYPE I (AT C/L)
LOCAL	40mm	50mm	150mm	375mm

NOTES

1. MINIMUM DEPTH OF UTILITIES IS 1.0m. WHERE ADDITIONAL GRANULAR ROAD SUBBASE IS USED, UTILITIES MUST BE LOWERED ACCORDINGLY.
2. DUE TO UNIQUE UTILITY LOCATIONS FOR THIS ROADWAY, CONSULTANT MUST LAYOUT/VERIFY ALL UTILITIES AND SUBMIT AS-BUILTS TO THE MUNICIPALITY.
3. JOINT UTILITY TRENCH COMPACTION SHALL BE VERIFIED BY THE GEOTECHNICAL ENGINEER PRIOR TO POURING SIDEWALK.

ALL DIMENSIONS ARE IN MILLIMETRES UNLESS OTHERWISE NOTED



**15.0m ROAD ALLOWANCE
URBAN**

REVISION NO.: 1
REVISION DATE: DECEMBER 2025

C-201

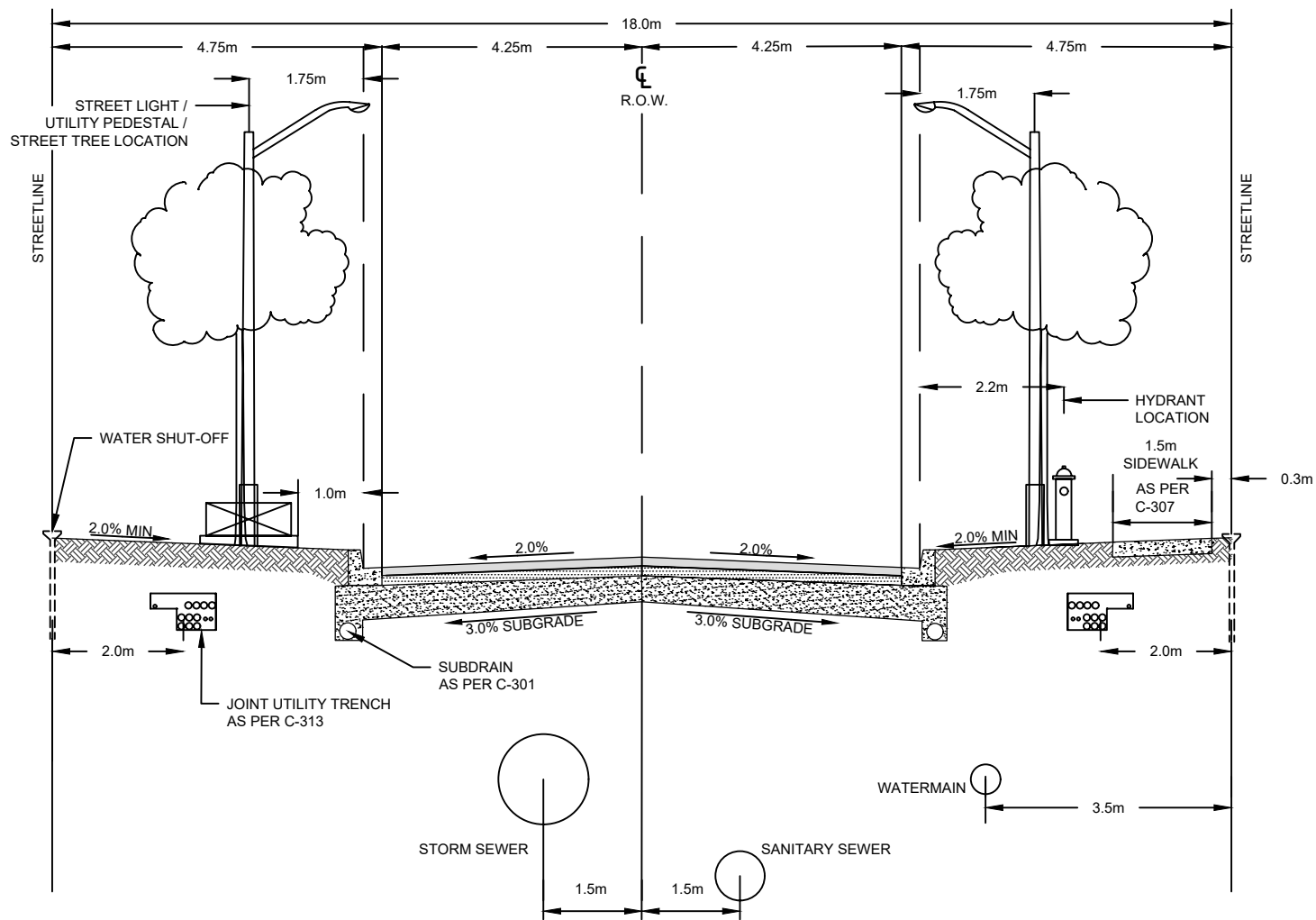

MINIMUM PAVEMENT DESIGN CRITERIA				
ROAD CLASS	SURFACE COURSE ASPHALT (HL3)	BASE COURSE ASPHALT (HL8)	GRANULAR 'A' 150mm	GRANULAR 'B' TYPE I (AT C/L) 375mm
LOCAL	40mm	50mm	150mm	375mm

NOTES

1. MINIMUM DEPTH OF UTILITIES IS 1.0m. WHERE ADDITIONAL GRANULAR ROAD SUBBASE IS USED, UTILITIES MUST BE LOWERED ACCORDINGLY.
2. DUE TO UNIQUE UTILITY LOCATIONS FOR THIS ROADWAY, CONSULTANT MUST LAYOUT/VERIFY ALL UTILITIES AND SUBMIT AS-BUILTS TO THE MUNICIPALITY.
3. JOINT UTILITY TRENCH COMPACTION SHALL BE VERIFIED BY THE GEOTECHNICAL ENGINEER PRIOR TO POURING SIDEWALK.
4. THIS DESIGN IS TO BE USED IN CONJUNCTION WITH 7.0m GARAGE SETBACKS ON NON-SIDEWALK SIDE.
5. HYDRO VAULTS SHALL ONLY BE PLACED ON THE NON-SIDEWALK SIDE.

ALL DIMENSIONS ARE IN MILLIMETRES UNLESS OTHERWISE NOTED



**18.0m ROAD ALLOWANCE
URBAN LOCAL ROAD**

REVISION NO.: 1
REVISION DATE: DECEMBER 2025

C-202

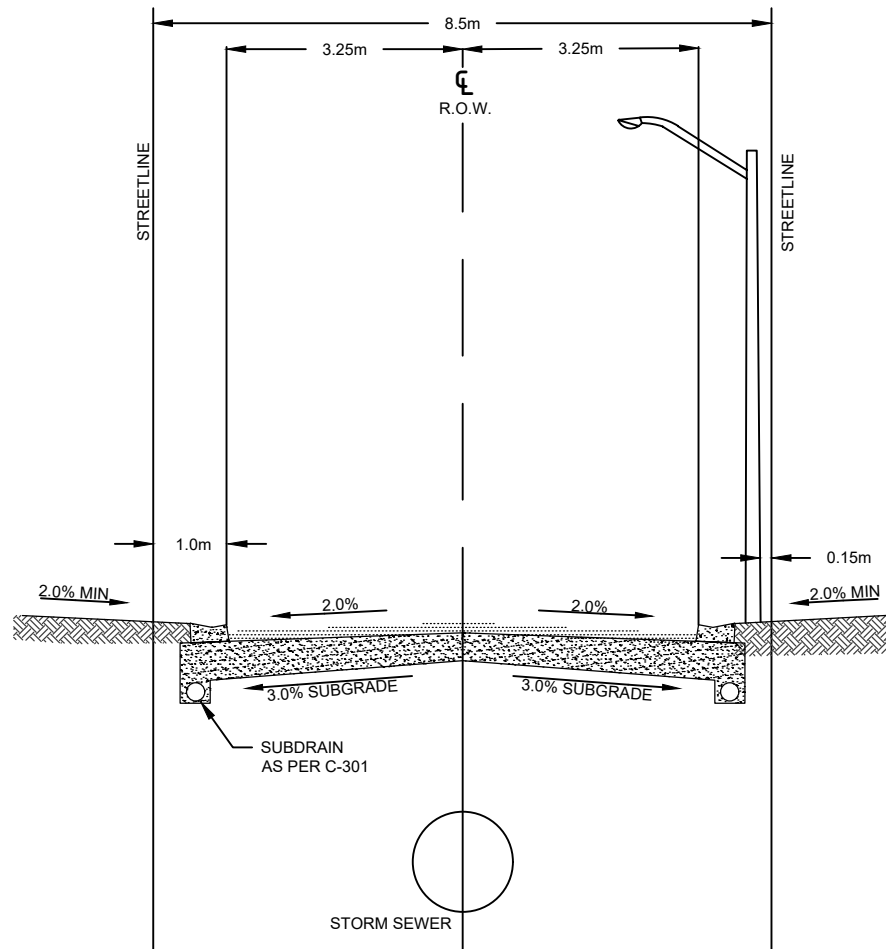

MINIMUM PAVEMENT DESIGN CRITERIA				
ROAD CLASS	SURFACE COURSE ASPHALT (HL3)	BASE COURSE ASPHALT (HL8)	GRANULAR 'A' TYPE I (AT C/L)	GRANULAR 'B' TYPE I (AT C/L)
LOCAL	40mm	50mm	150mm	375mm

NOTES

1. MINIMUM DEPTH OF UTILITIES IS 1.0m. WHERE ADDITIONAL GRANULAR ROAD SUBBASE IS USED, UTILITIES MUST BE LOWERED ACCORDINGLY.
2. DUE TO UNIQUE UTILITY LOCATIONS FOR THIS ROADWAY, CONSULTANT MUST LAYOUT/VERIFY ALL UTILITIES AND SUBMIT AS-BUILTS TO THE MUNICIPALITY.
3. JOINT UTILITY TRENCH COMPACTION SHALL BE VERIFIED BY THE GEOTECHNICAL ENGINEER PRIOR TO POURING SIDEWALK.
4. THIS DESIGN IS TO BE USED IN CONJUNCTION WITH 7.0m GARAGE SETBACKS ON NON-SIDEWALK SIDE.
5. HYDRO VAULTS SHALL ONLY BE PLACED ON THE NON-SIDEWALK SIDE.
6. SEMI-MOUNTABLE CURB AND GUTTER SHALL BE AS PER OPSD 600.060.

ALL DIMENSIONS ARE IN MILLIMETRES UNLESS OTHERWISE NOTED



**8.5m ROAD ALLOWANCE
LANEWAY**

REVISION NO.: 1
REVISION DATE: DECEMBER 2025

C-203

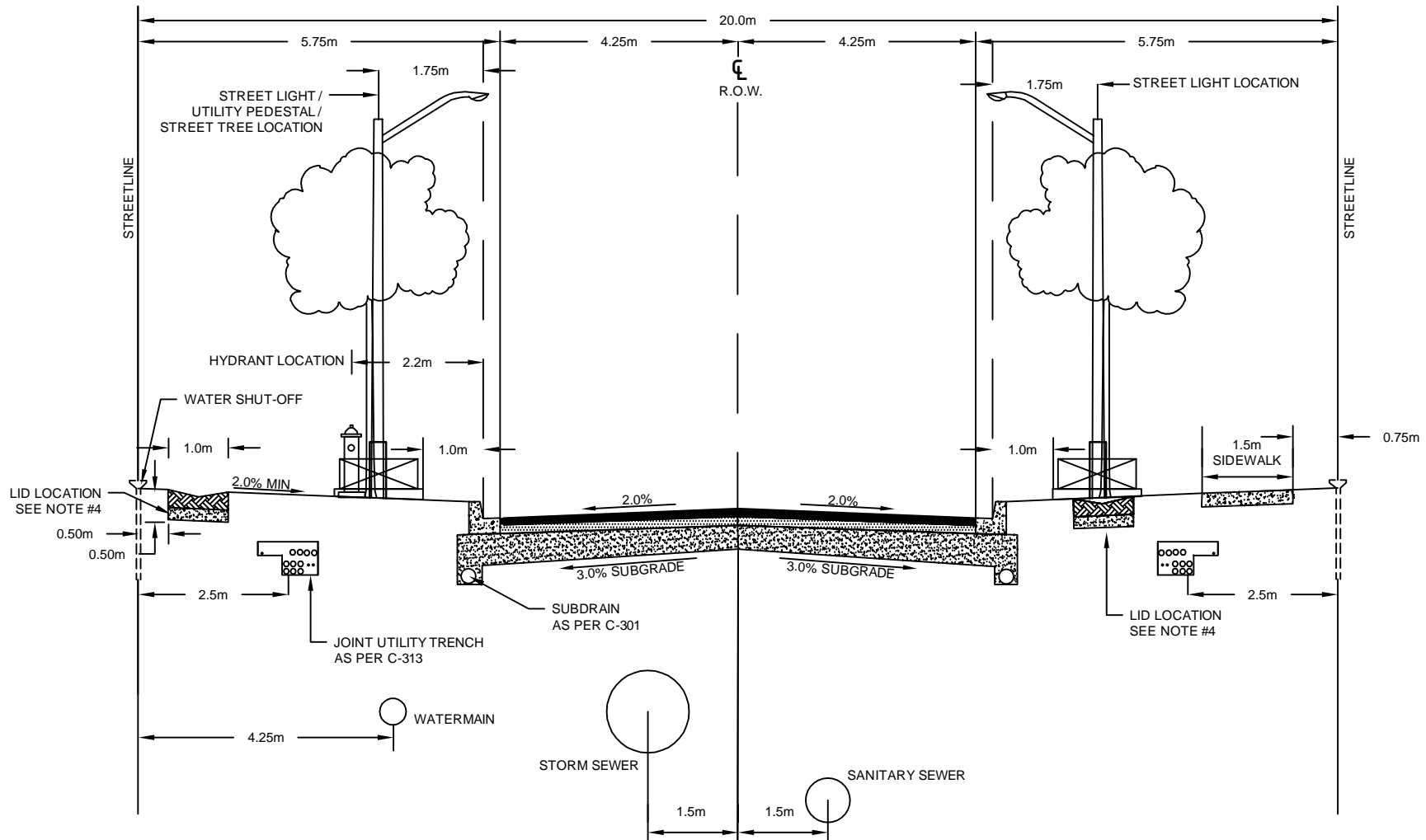

MINIMUM PAVEMENT DESIGN CRITERIA

ROAD CLASS	SURFACE COURSE ASPHALT (HL3)	BASE COURSE ASPHALT (HL8)	GRANULAR 'A'	GRANULAR 'B' TYPE I (AT C/L)
LOCAL	40mm	50mm	150mm	375mm

NOTES

1. MINIMUM DEPTH OF UTILITIES IS 1.0m. WHERE ADDITIONAL GRANULAR ROAD SUBBASE IS USED, UTILITIES MUST BE LOWERED ACCORDINGLY.
2. DUE TO UNIQUE UTILITY LOCATIONS FOR THIS ROADWAY, CONSULTANT MUST LAYOUT/VERIFY ALL UTILITIES AND SUBMIT AS-BUILTS TO THE MUNICIPALITY.
3. JOINT UTILITY TRENCH COMPACTION SHALL BE VERIFIED BY THE GEOTECHNICAL ENGINEER PRIOR TO POURING SIDEWALK.
4. LID LOCATION, TYPE AND SIZE TO BE DETERMINED BY DETAILED DESIGN.

ALL DIMENSIONS ARE IN MILLIMETRES UNLESS OTHERWISE NOTED



**20.0m ROAD ALLOWANCE
URBAN LOCAL ROAD**

REVISION NO.: 1
REVISION DATE: DECEMBER 2025

C-204

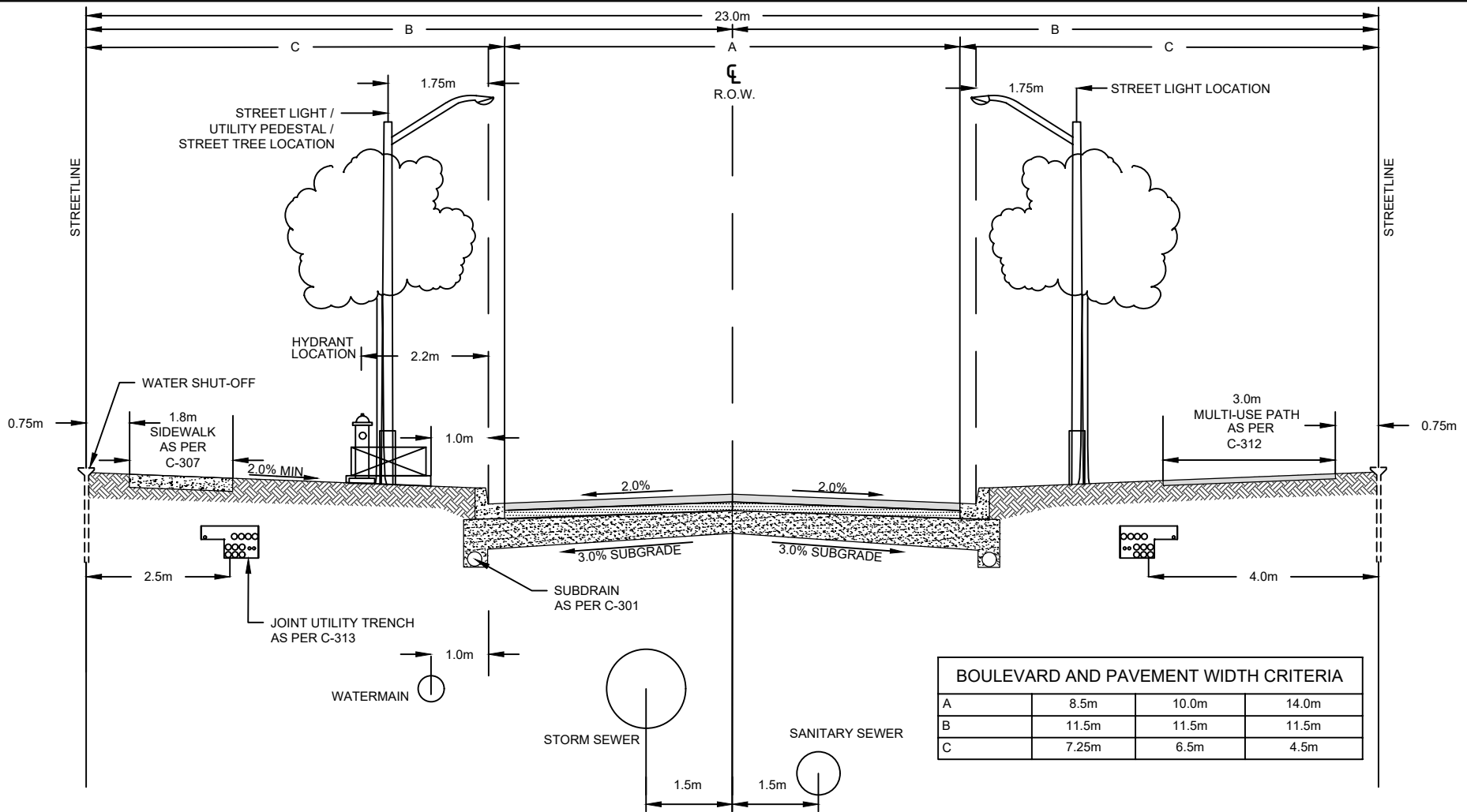

BOULEVARD AND PAVEMENT WIDTH CRITERIA			
A	8.5m	10.0m	14.0m
B	11.5m	11.5m	11.5m
C	7.25m	6.5m	4.5m

MINIMUM PAVEMENT DESIGN CRITERIA				
ROAD CLASS	SURFACE COURSE ASPHALT (HL3)	BASE COURSE ASPHALT (HL8)	GRANULAR 'A'	GRANULAR 'B' TYPE I (AT C/L)
LOCAL	40mm	90mm (SEE NOTE 4)	150mm	375mm
COLLECTOR	40mm	100mm - 2 LIFTS	150mm	450mm

NOTES

1. MINIMUM DEPTH OF UTILITIES IS 1.0m. WHERE ADDITIONAL GRANULAR ROAD SUBBASE IS USED, UTILITIES MUST BE LOWERED ACCORDINGLY.
2. DUE TO UNIQUE UTILITY LOCATIONS FOR THIS ROADWAY, CONSULTANT MUST LAYOUT/VERIFY ALL UTILITIES AND SUBMIT AS-BUILTS TO THE MUNICIPALITY.
3. JOINT UTILITY TRENCH COMPACTION SHALL BE VERIFIED BY THE GEOTECHNICAL ENGINEER PRIOR TO POURING SIDEWALK.
4. HL8 PLACEMENT TO BE COMPLETED IN TWO LIFTS, 50mm AND 40mm

ALL DIMENSIONS ARE IN MILLIMETRES UNLESS OTHERWISE NOTED



**23.0m ROAD ALLOWANCE
URBAN COLLECTOR ROAD**

REVISION NO.: 1
REVISION DATE: DECEMBER 2025

C-205

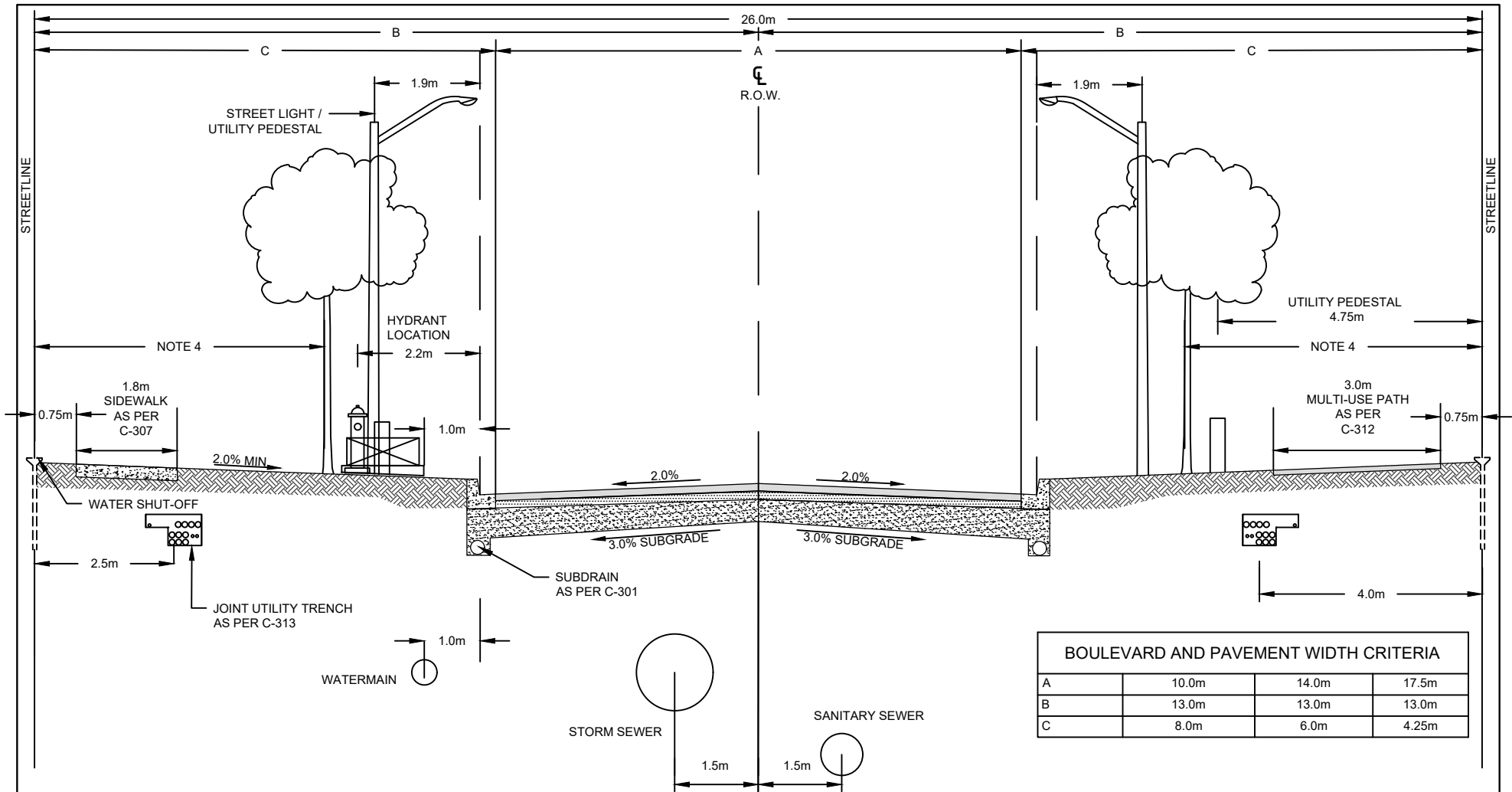

NOTES

1. MINIMUM DEPTH OF UTILITIES IS 1.0m. WHERE ADDITIONAL GRANULAR ROAD SUBBASE IS USED, UTILITIES MUST BE LOWERED ACCORDINGLY.
2. DUE TO UNIQUE UTILITY LOCATIONS FOR THIS ROADWAY, CONSULTANT MUST LAYOUT/VERIFY ALL UTILITIES AND SUBMIT AS-BUILTS TO THE MUNICIPALITY.
3. JOINT UTILITY TRENCH COMPACTION SHALL BE VERIFIED BY THE GEOTECHNICAL ENGINEER PRIOR TO POURING SIDEWALK.
4. TREE LOCATION TO BE CENTERED BETWEEN FACE OF CURB AND SIDEWALK OR MULTI-USE PATH.

ALL DIMENSIONS ARE IN MILLIMETRES UNLESS OTHERWISE NOTED

BOULEVARD AND PAVEMENT WIDTH CRITERIA			
A	10.0m	14.0m	17.5m
B	13.0m	13.0m	13.0m
C	8.0m	6.0m	4.25m

MINIMUM PAVEMENT DESIGN CRITERIA				
ROAD CLASS	SURFACE COURSE ASPHALT (HL3)	BASE COURSE ASPHALT (HL8/HDBC)	GRANULAR 'A'	GRANULAR 'B' TYPE I (AT C/L)
COLLECTOR	40mm	100mm (HL8) - 2 LIFTS	150mm	375mm
ARTERIAL TYPE 'C'	40mm	100mm (HDBC) - 2 LIFTS	150mm	600mm



**26.0m ROAD ALLOWANCE
URBAN ROAD**

REVISION NO.: 1
REVISION DATE: DECEMBER 2025

C-206

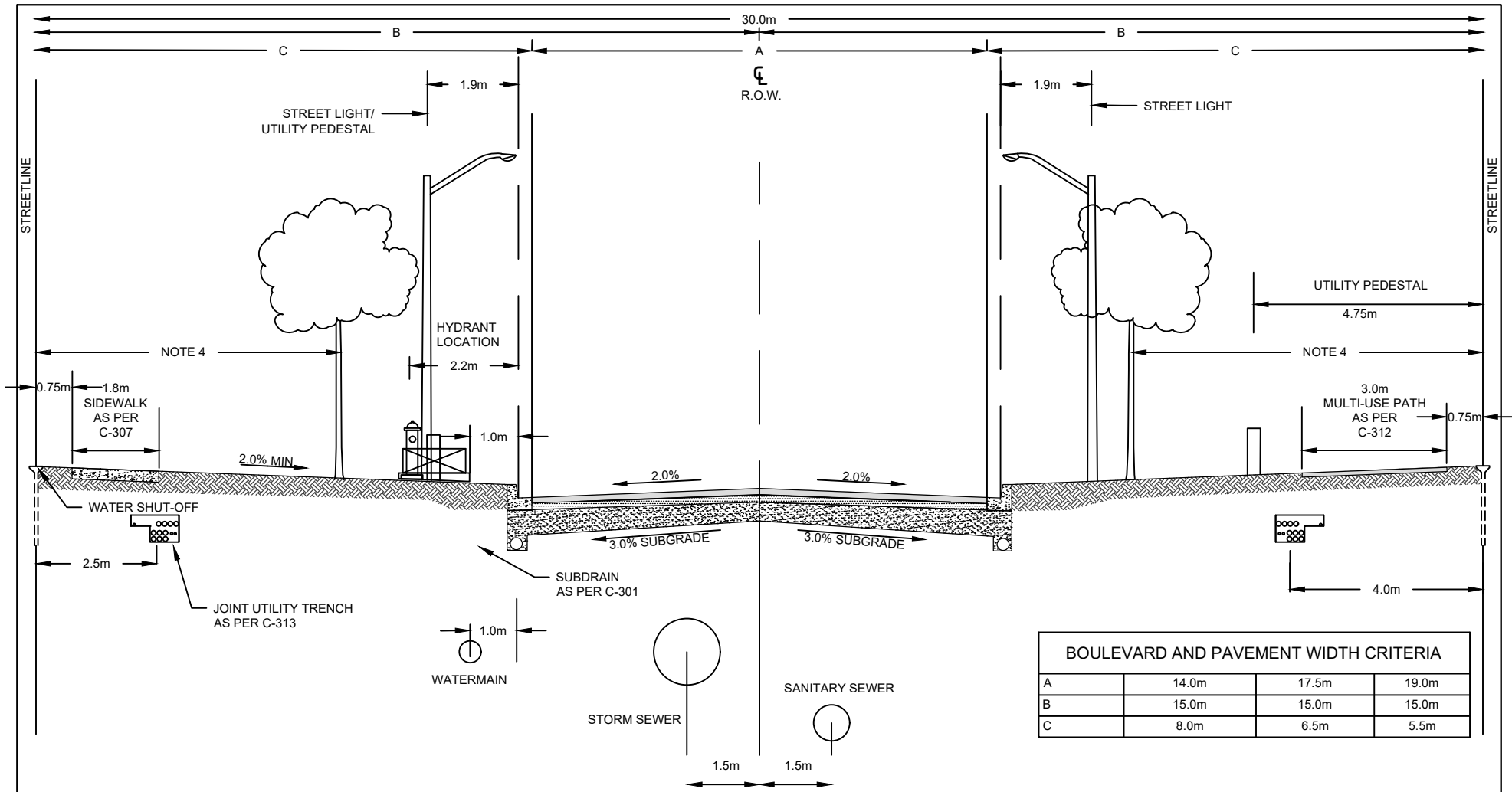

BOULEVARD AND PAVEMENT WIDTH CRITERIA			
A	14.0m	17.5m	19.0m
B	15.0m	15.0m	15.0m
C	8.0m	6.5m	5.5m

MINIMUM PAVEMENT DESIGN CRITERIA				
ROAD CLASS	SURFACE COURSE ASPHALT (HL3)	BASE COURSE ASPHALT (HL8/HDBC)	GRANULAR 'A'	GRANULAR 'B' TYPE I (AT C/L)
ARTERIAL TYPE 'C'	40mm	100mm (HDBC) 2 LIFTS	150mm	600mm

NOTES

1. MINIMUM DEPTH OF UTILITIES IS 1.0m. WHERE ADDITIONAL GRANULAR ROAD SUBBASE IS USED, UTILITIES MUST BE LOWERED ACCORDINGLY.
2. DUE TO UNIQUE UTILITY LOCATIONS FOR THIS ROADWAY, CONSULTANT MUST LAYOUT/VERIFY ALL UTILITIES AND SUBMIT AS-BUILTS TO THE MUNICIPALITY.
3. JOINT UTILITY TRENCH COMPACTION SHALL BE VERIFIED BY THE GEOTECHNICAL ENGINEER PRIOR TO POURING SIDEWALK.
4. TREE LOCATION TO BE CENTERED BETWEEN FACE OF CURB AND SIDEWALK OR MULTI-USE PATH.

ALL DIMENSIONS ARE IN MILLIMETRES UNLESS OTHERWISE NOTED



**30.0m ROAD ALLOWANCE
ARTERIAL URBAN ROAD**

REVISION NO.: 1
REVISION DATE: DECEMBER 2025

C-207

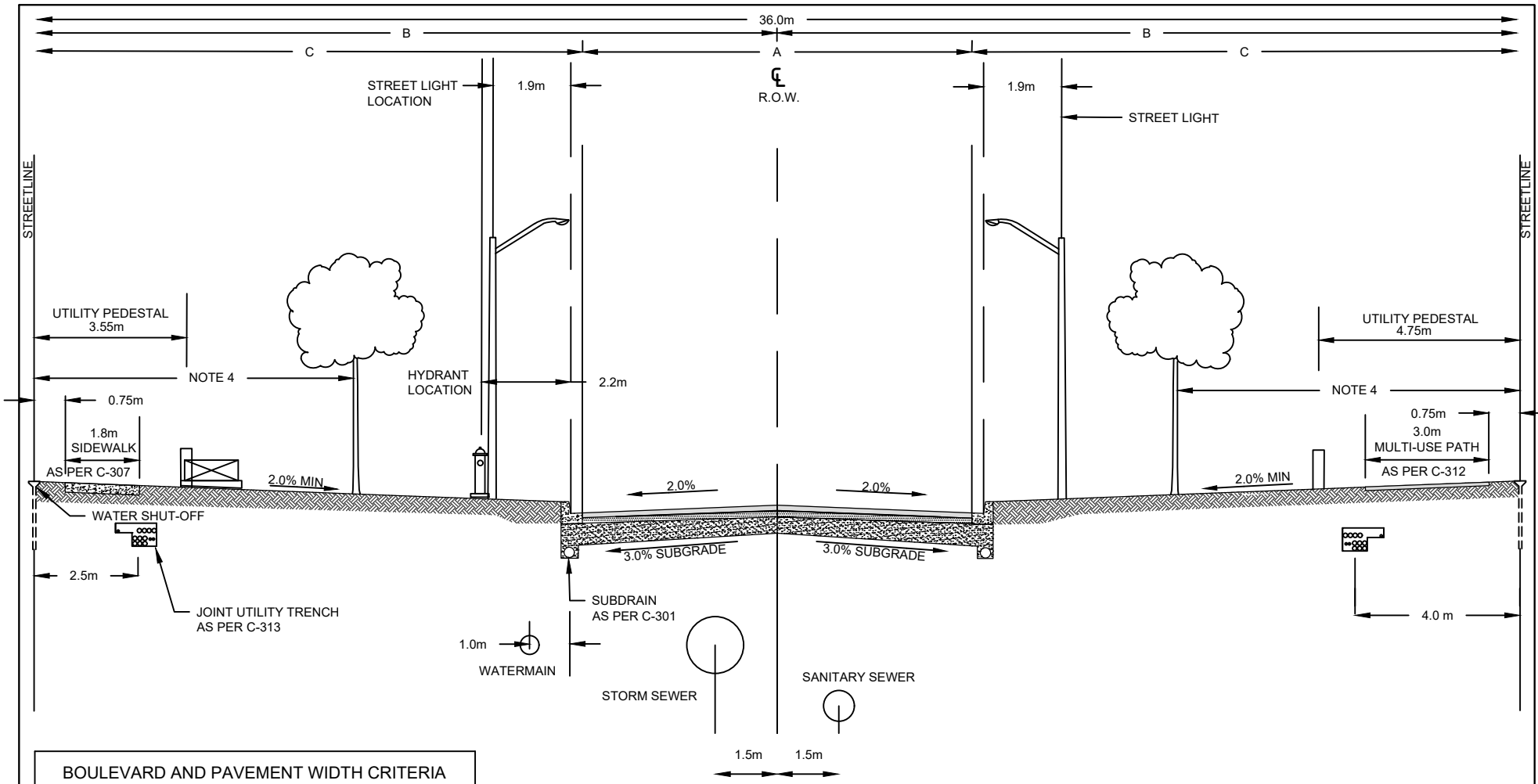

BOULEVARD AND PAVEMENT WIDTH CRITERIA

	14.0m	17.5m	19.0m
A			
B	18.0m	18.0m	18.0m
C	11.0m	9.5m	8.5m

MINIMUM PAVEMENT DESIGN CRITERIA

ROAD CLASS	SURFACE COURSE ASPHALT (HL3)	BASE COURSE ASPHALT (HL8/HDBC)	GRANULAR 'A'	GRANULAR 'B' TYPE I (AT C/L)
ARTERIAL TYPE 'C'	40mm	100mm (HDBC) 2 LIFTS	150mm	600mm

NOTES

1. MINIMUM DEPTH OF UTILITIES IS 1.0m. WHERE ADDITIONAL GRANULAR ROAD SUBBASE IS USED, UTILITIES MUST BE LOWERED ACCORDINGLY.
2. DUE TO UNIQUE UTILITY LOCATIONS FOR THIS ROADWAY, CONSULTANT MUST LAYOUT/VERIFY ALL UTILITIES AND SUBMIT AS-BUILTS TO THE MUNICIPALITY.
3. JOINT UTILITY TRENCH COMPACTION SHALL BE VERIFIED BY THE GEOTECHNICAL ENGINEER PRIOR TO POURING SIDEWALK.
4. TREE LOCATION TO BE CENTERED BETWEEN FACE OF CURB AND SIDEWALK OR MULTI-USE PATH.

ALL DIMENSIONS ARE IN MILLIMETRES UNLESS OTHERWISE NOTED



**36.0m ROAD ALLOWANCE
ARTERIAL URBAN ROAD**

REVISION NO.: 1
REVISION DATE: DECEMBER 2025

C-208

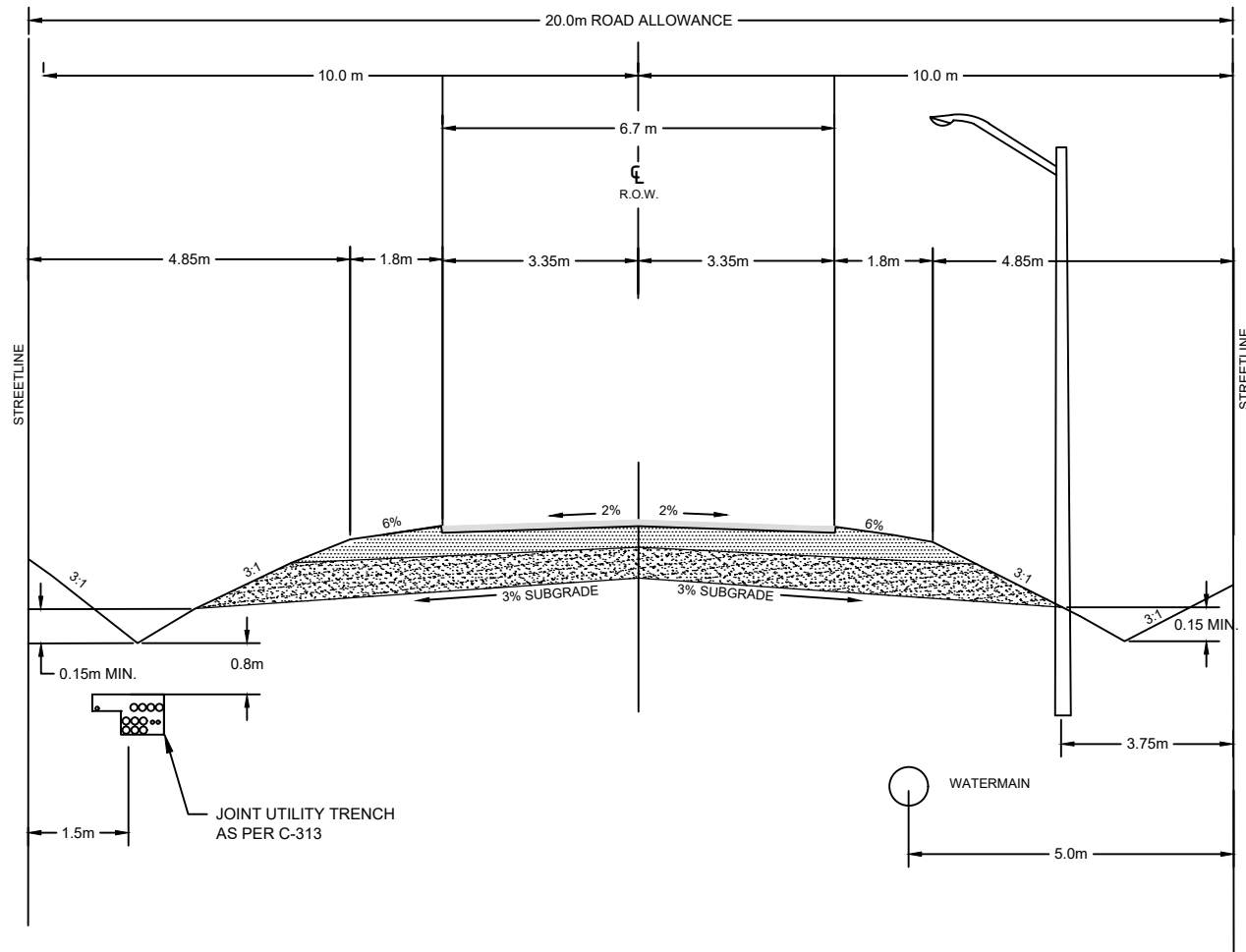

NOTES

1. ALL DITCHES TO HAVE TOPSOIL AND SOD (STAKED WHERE NECESSARY)

MINIMUM PAVEMENT DESIGN CRITERIA				
ROAD CLASS	SURFACE COURSE ASPHALT (HL3)	BASE COURSE ASPHALT (HL8)	GRANULAR 'A' 150mm	GRANULAR 'B' TYPE I (AT C/L)
LOCAL	40mm	50mm	150mm	375mm

ALL DIMENSIONS ARE IN MILLIMETRES UNLESS OTHERWISE NOTED



**20.0m ROAD ALLOWANCE
6.7m PAVEMENT WIDTH (RURAL)**

REVISION NO.: 1
REVISION DATE: DECEMBER 2025

C-209

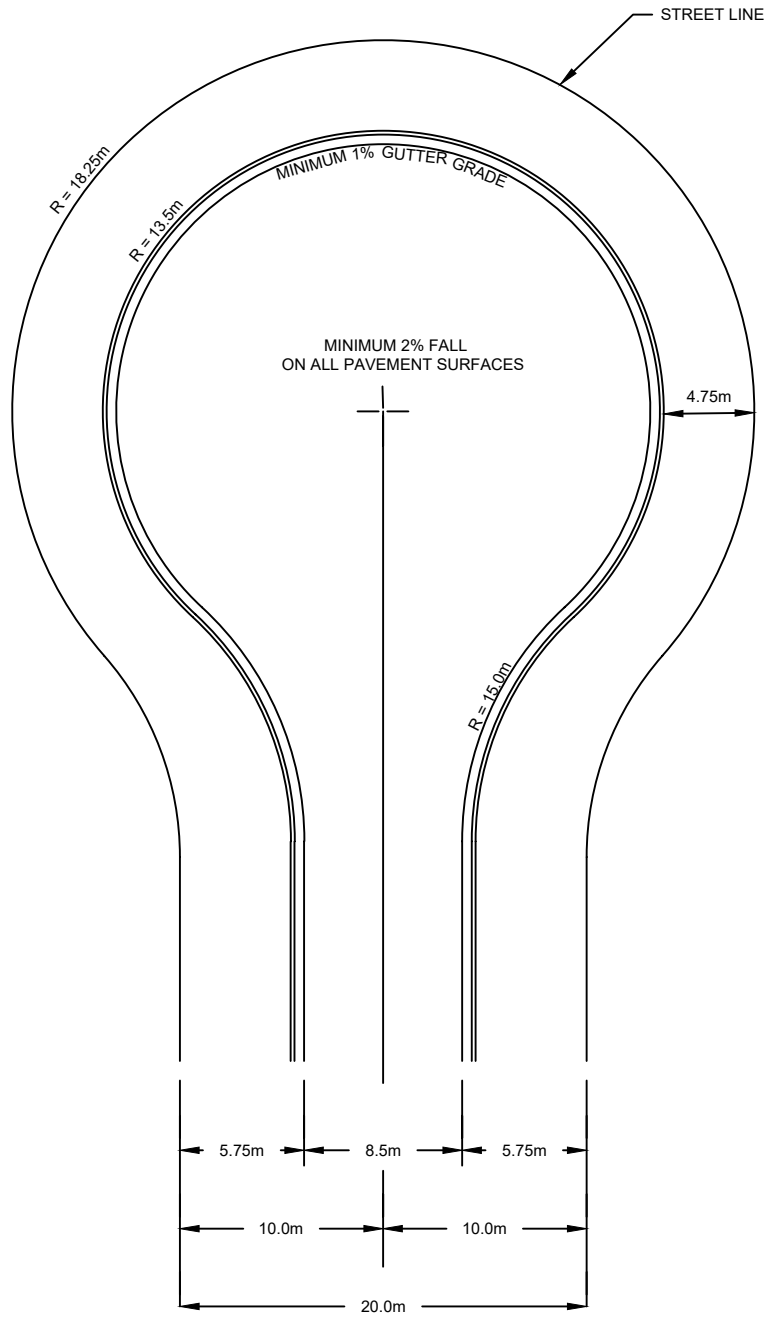

MINIMUM PAVEMENT DESIGN CRITERIA	
SURFACE COURSE ASPHALT (HL3)	40mm
BASE COURSE ASPHALT (HL8)	50mm
GRANULAR 'A'	150mm
GRANULAR 'B'	375mm

ALL DIMENSIONS ARE IN MILLIMETRES UNLESS OTHERWISE NOTED

Clarington

**CUL-DE-SAC
FOR URBAN RESIDENTIAL STREETS**

REVISION NO.: 1
REVISION DATE: DECEMBER 2025

C-211

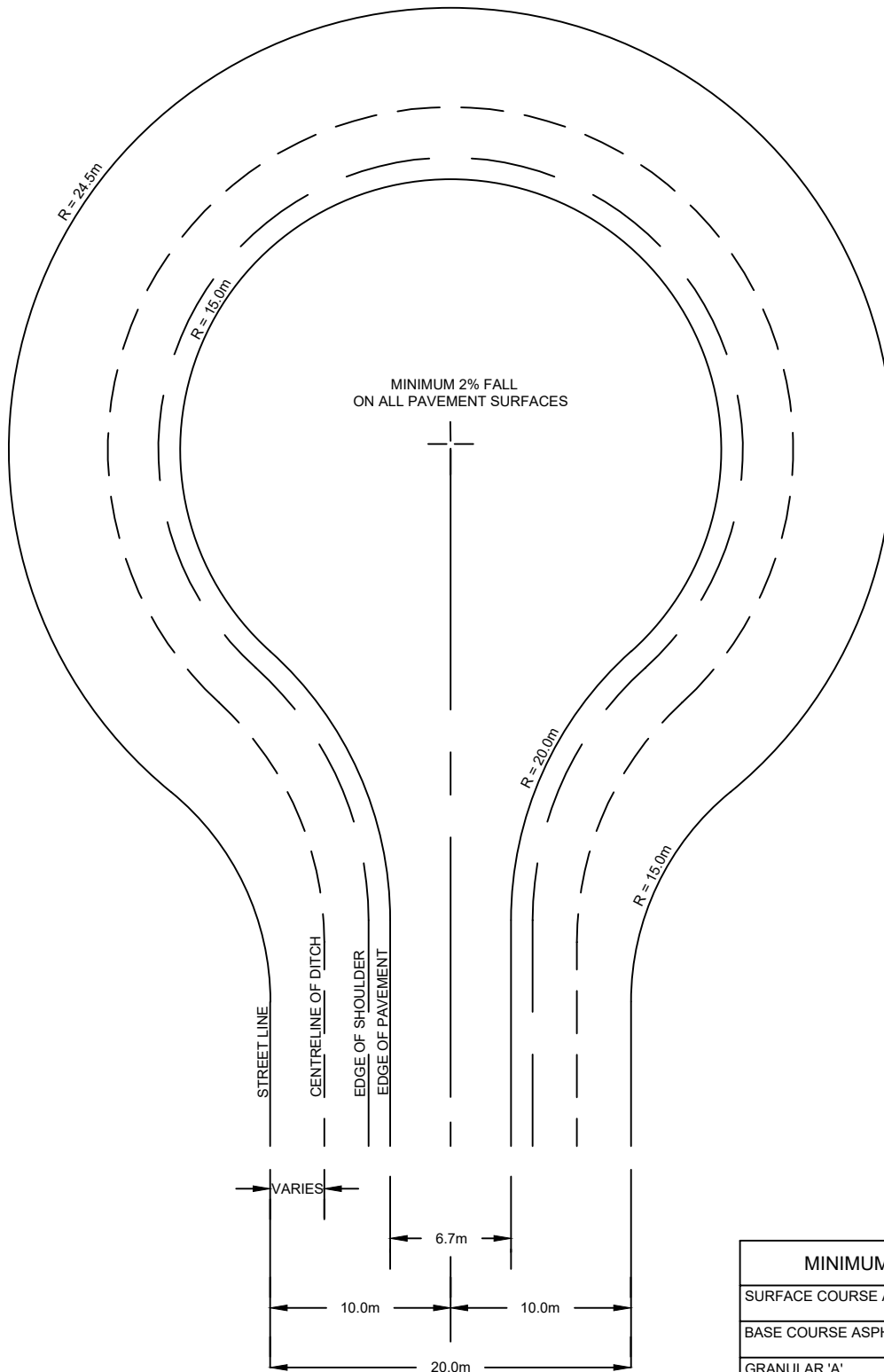

MINIMUM PAVEMENT DESIGN	
SURFACE COURSE ASPHALT (HL3)	40mm
BASE COURSE ASPHALT (HL8)	50mm
GRANULAR 'A'	150mm
GRANULAR 'B'	375mm

NOTES

THIS STANDARD TO BE READ IN CONJUNCTION WITH STD. C-209

ALL DIMENSIONS ARE IN MILLIMETRES UNLESS OTHERWISE NOTED



**CUL-DE-SAC
FOR RURAL RESIDENTIAL STREETS**

REVISION NO.: 1
REVISION DATE: DECEMBER 2025

C-212

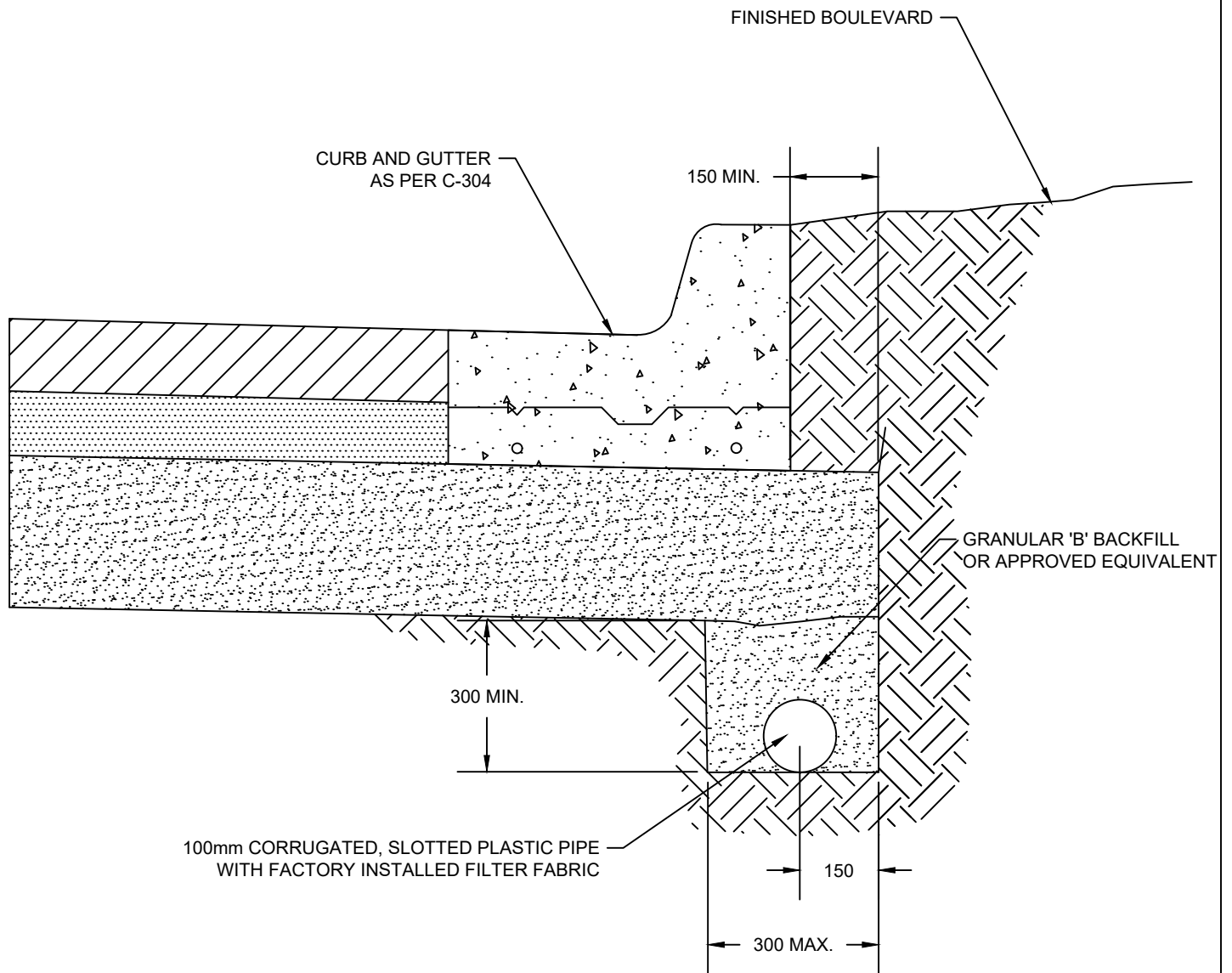

NOTES

1. SUBDRAINS ARE TO RUN CONTINUOUS ON BOTH SIDES OF ROAD.
2. ALL SUBDRAINS SHALL HAVE SUFFICIENT GRADE TO DRAIN INTO CATCHBASIN.
3. SUBDRAINS ARE TO BE INSTALLED IN A TRENCH CONDITION.
4. IF ADDITIONAL DEPTH ROAD GRANULARS ARE REQUIRED, SUBDRAINS MUST BE LOWERED ACCORDINGLY.
5. APPROVED MANUFACTURER CONNECTIONS ARE TO BE USED WHEN SPLICING SECTIONS TOGETHER.

ALL DIMENSIONS ARE IN MILLIMETRES UNLESS OTHERWISE NOTED

REVISION NO.: 1
REVISION DATE: DECEMBER 2025

Clarington

PERFORATED PLASTIC SUBDRAINS

C-301

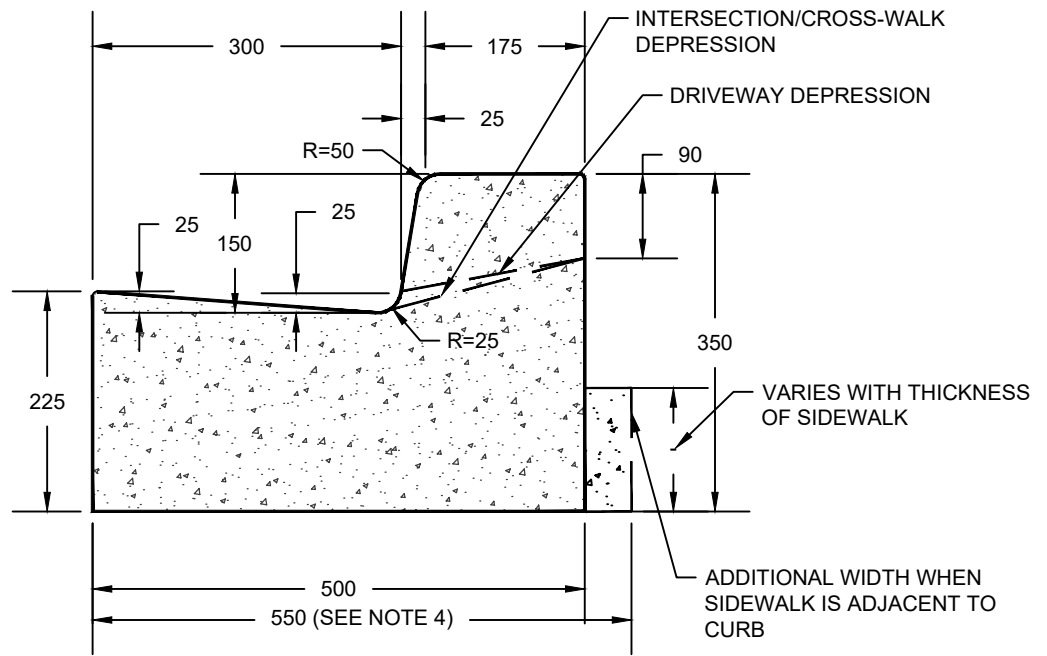

STANDARD CURB AND GUTTER

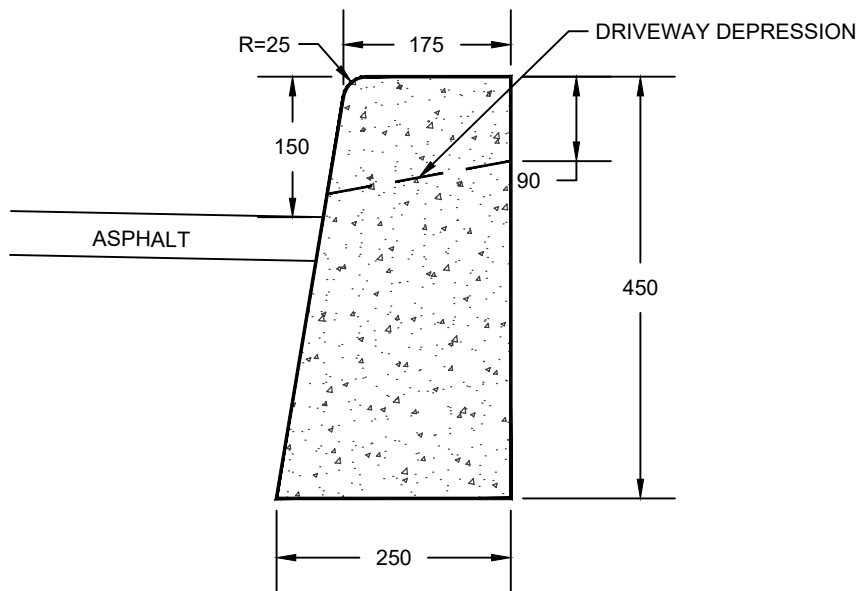

BARRIER CURB

NOTES

1. CONCRETE SHALL CONFORM TO OPSS MUNI 353 AND 1350 SPECIFICATIONS (32MPa, 5.0% TO 8.0% AIR).
2. CONTRACTION JOINTS TO BE SAWCUT EVERY 3.0m (MAXIMUM) AND TO BE 25% OF TOTAL DEPTH.
3. CURING COMPOUND TO BE APPLIED TO ALL EXPOSED SURFACES WITHIN HALF HOUR OF FINISHING. IF CONCRETE IS INITIALLY CURED WITH OTHER METHODS DUE TO THE WEATHER CONDITIONS, CURING COMPOUND SHALL BE APPLIED WITH 24 HOURS OF FINISHING.
4. ADDITIONAL WIDTH REQUIRED WHERE CURB IS ADJACENT TO SIDEWALK.
5. SEMI-MOUNTABLE CURB AND GUTTER SHALL BE AS PER OPSD 600.060.
6. COLD WEATHER PROTECTION SHALL BE USED WHEN DAY TIME TEMPERATURES ARE EXPECTED TO BE BELOW 5° CELSIUS DURING THE CURING PERIOD AS NOTED IN OPSS MUNI 904.

ALL DIMENSIONS ARE IN MILLIMETRES UNLESS OTHERWISE NOTED

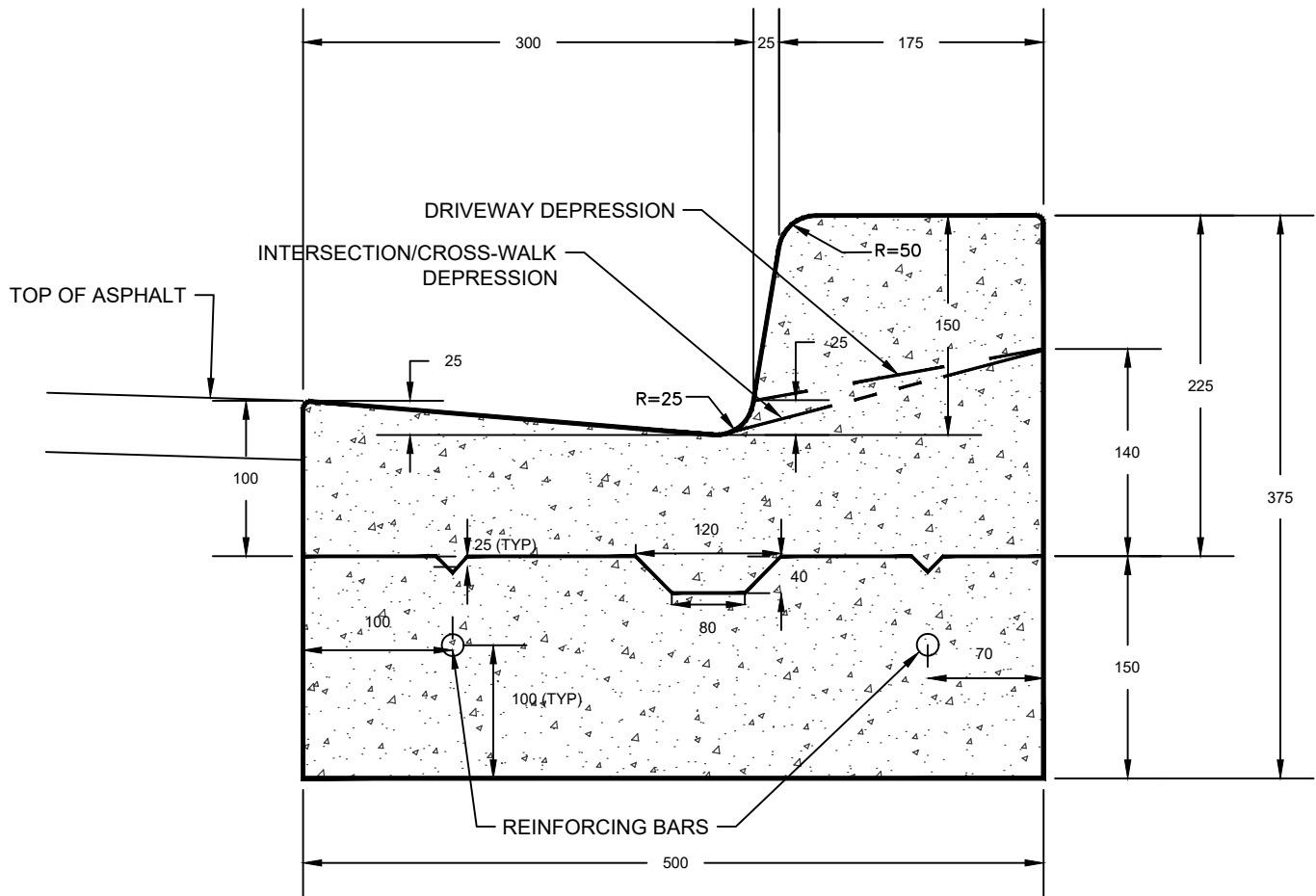

NOTES

1. CONCRETE SHALL CONFORM TO OPSS MUNI 353 AND 1350 SPECIFICATIONS (32MPa, 5.0% TO 8.0% AIR).
2. FIRST STAGE CURB TO BE A CONTINUOUS POUR. SECOND STAGE CONTRACTION JOINTS TO BE SAWCUT EVERY 3.0m (MAXIMUM) AND TO BE 25% OF TOTAL DEPTH.
3. CURING: STAGE 1 & STAGE 2 - CURING COMPOUND - TO BE APPLIED WITHIN HALF HOUR OF FINISHING ON ALL EXPOSED SURFACES.
4. STAGE 1 TO BE THOROUGHLY CLEANED AND WET PRIOR TO STAGE 2 INSTALLATION.
5. ALL REINFORCING TO HAVE 50mm COVER.
6. REINFORCING BAR IN BASE IS 15M ON STRAIGHT AND 10M ON CURVES.
7. BASE ASPHALT TO TO BE SAWCUT SUFFICIENTLY TO ALLOW FOR MECHANICAL COMPACTION OF HL3 FILLER.
8. EXCESS CONCRETE TO BE REMOVED IMMEDIATELY AT TIME OF POURING.
9. IF CONCRETE IS INITIALLY CURED WITH OTHER METHODS DUE TO THE WEATHER CONDITIONS, CURING COMPOUND SHALL BE APPLIED WITHIN 24 HOURS OF FINISHING ON ALL EXPOSED SURFACES.
10. COLD WEATHER PROTECTION SHALL BE USED WHEN DAY TIME TEMPERATURES ARE EXPECTED TO BE BELOW 5° CELSIUS DURING THE CURING COMPOUND PERIOD AS NOTED IN OPSS MUNI 904.

ALL DIMENSIONS ARE IN MILLIMETRES UNLESS OTHERWISE NOTED

REVISION NO.: 1
REVISION DATE: DECEMBER 2025



**STANDARD TWO STAGE
CURB & GUTTER**

C-304

SAWCUT CURB FACE AT BACK OF FRAME

MIN. 1.0m

MIN. 1.0m

15
GRADE CHANGE TO CB FRAME ACROSS INFILL

FULL DEPTH EXPANSION JOINT

FULL DEPTH EXPANSION JOINT

CATCH BASIN TO BE CORRECTLY ALIGNED WITH PRECAST

CONCRETE TOP ROW ONLY (SEE NOTE 2).
USE MANUFACTURERS SEALANT TAPE BETWEEN ROWS AND AT PRECAST.

ADJUSTMENT UNITS,
MIN. ONE, MAX. 300mm

ONLY PLASTIC SHIMS WILL BE ALLOWED FOR ADJUSTMENT STAGE

WRAP OUTSIDE OF BRICKWORK SURFACES ENTIRELY WITH WATERPROOF MEMBRANE SO THAT IT OVERLAPS TOP OF PRECAST AND FRAME

FULL DEPTH EXPANSION JOINT

REMOVAL AREA

MIN. 1.0m

SAWCUT CURB FACE AT BACK OF FRAME

300

MIN. 1.0m

FULL DEPTH EXPANSION JOINT

NOTES

1. FOR GRATE SPECIFICATIONS SEE OPSD 400.010.
2. MORTAR FOR ADJUSTMENTS TO BE SPEEDCRETE OR APPROVED EQUIVALENT.
3. STAGE 1 - CURB TO BE BROUGHT UP CLOSE TO STRUCTURE. TEMPORARY ASPHALT FILLER AROUND CATCH BASIN INCLUDING CURB.
4. STAGE 2 - REMOVE ASPHALT FILLER. CUT CURB WITH PLUNGE SAW MINIMUM 1.0m BACK FROM STRUCTURE AND COMPLETE CURB IN ONE POUR.
5. CATCH BASINS ARE TO BE INSTALLED IN PRECISE ALIGNMENT WITH CURBLINES. NO TOLERANCES WILL BE PERMITTED.

ALL DIMENSIONS ARE IN MILLIMETRES UNLESS OTHERWISE NOTED

REVISION NO.: 1

REVISION DATE: DECEMBER 2025



CURB AND GUTTER DETAIL AT CATCH BASIN

C-305

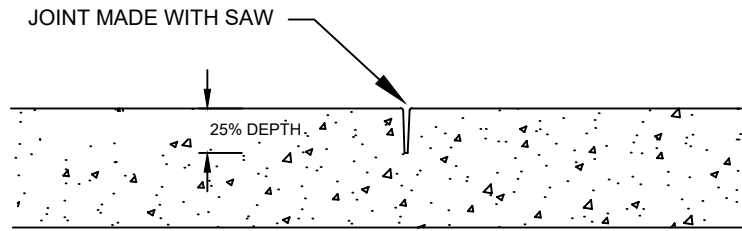

TYPICAL CONTRACTION JOINT

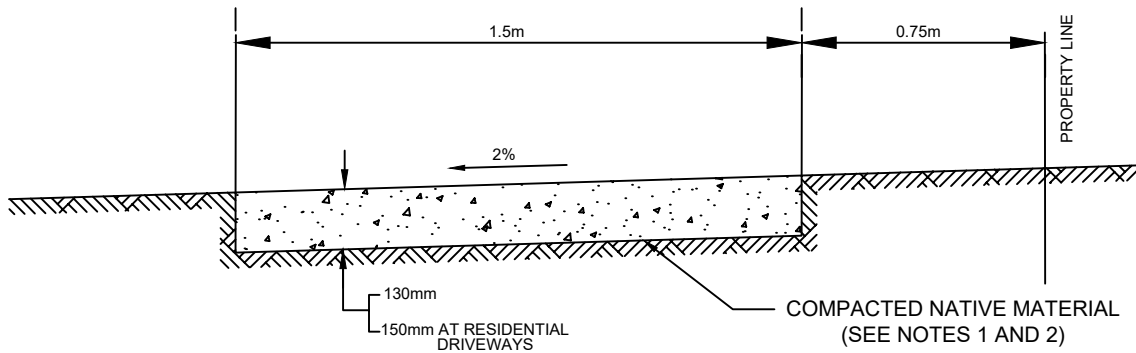
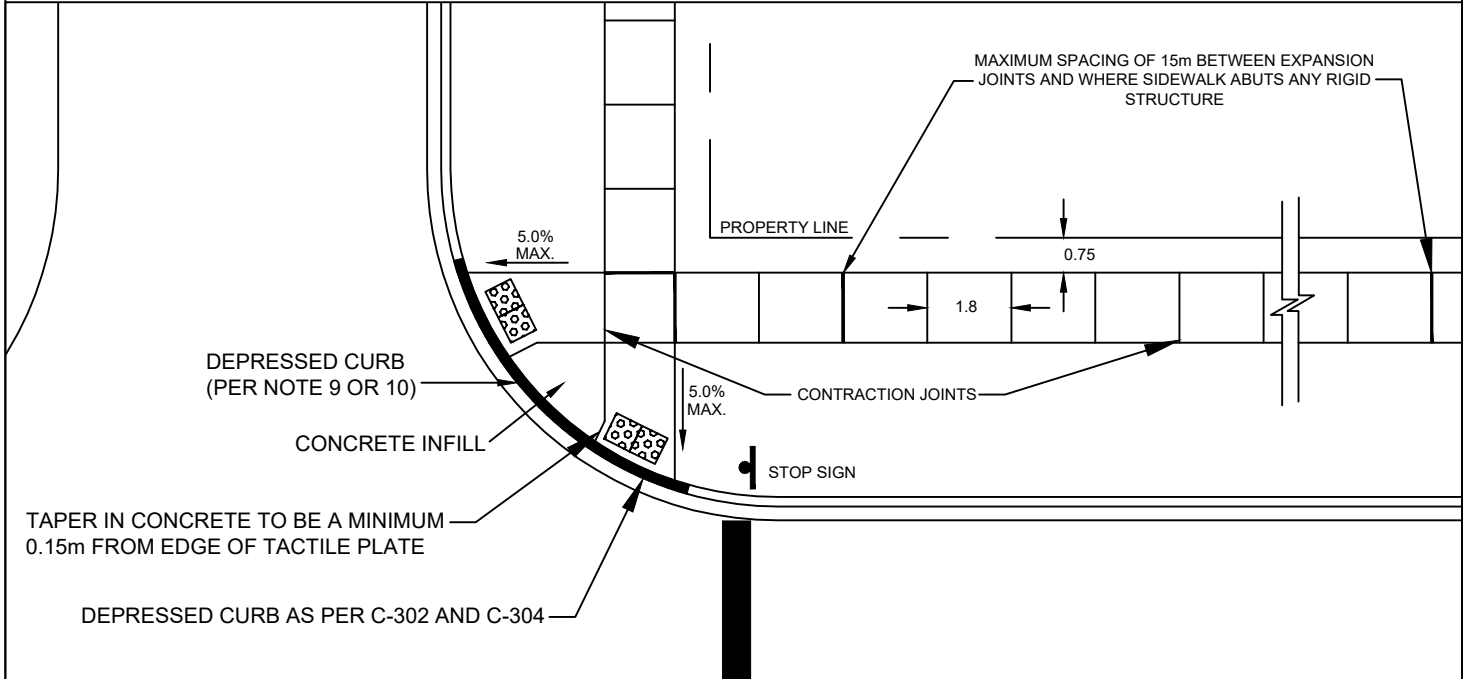

NOTES

1. USE 100mm COMPACTED GRANULAR 'A' IF NATIVE MATERIAL IS DEEMED UNACCEPTABLE BY THE MUNICIPALITY.
2. SUBGRADE MATERIAL TO BE WELL COMPACTED, THEN DAMPENED IMMEDIATELY PRIOR TO POURING SIDEWALK.
3. CONCRETE SHALL CONFORM TO OPSS SPECIFICATIONS (32MPa, 5.0% TO 8.0% AIR).
4. CURING COMPOUND SHALL BE APPLIED WITHIN 30 MINUTES OF FINISHING ON ALL EXPOSED SURFACES.
5. EXPANSION JOINTS TO BE PLACED TO FULL DEPTH OF SIDEWALK.
6. SAW CUT CONTRACTION JOINTS TO BE 25% DEPTH OF SIDEWALK.
7. SURFACE OF SIDEWALK TO HAVE AN EVEN, CONTINUOUS BROOM FINISH WITH A TOOLED OUTSIDE EDGE.
8. TACTILE PLATES TO BE INSTALLED AT ALL INTERSECTION CROSSINGS AND WILL FOLLOW THE BACK OF CURB AT THE DISCRETION OF THE MUNICIPALITY.
9. IF THE DISTANCE BETWEEN THE INSIDE EDGE OF THE CURB DEPRESSIONS IS 3.3m OR GREATER, A 1.5m WIDE FLARED SIDE RAMP AT 10:1 SLOPE WILL BE INSTALLED BETWEEN DEPRESSIONS COMPLETE WITH 0.3m WIDE PLATFORM WITH FULL CURB.
10. IF THE DISTANCE BETWEEN THE INSIDE EDGE OF THE CURB DEPRESSION IS LESS THAN 3.3m THE FULL RADIUS IS TO BE DEPRESSED AND TACTILE PLATES ARE TO BE INSTALLED TO MATCH THE BACK OF THE CURB ACROSS THE FULL DEPRESSION.

ALL DIMENSIONS ARE IN MILLIMETRES UNLESS OTHERWISE NOTED

REVISION NO.: 1
REVISION DATE: DECEMBER 2025



STANDARD CONCRETE SIDEWALK

C-307

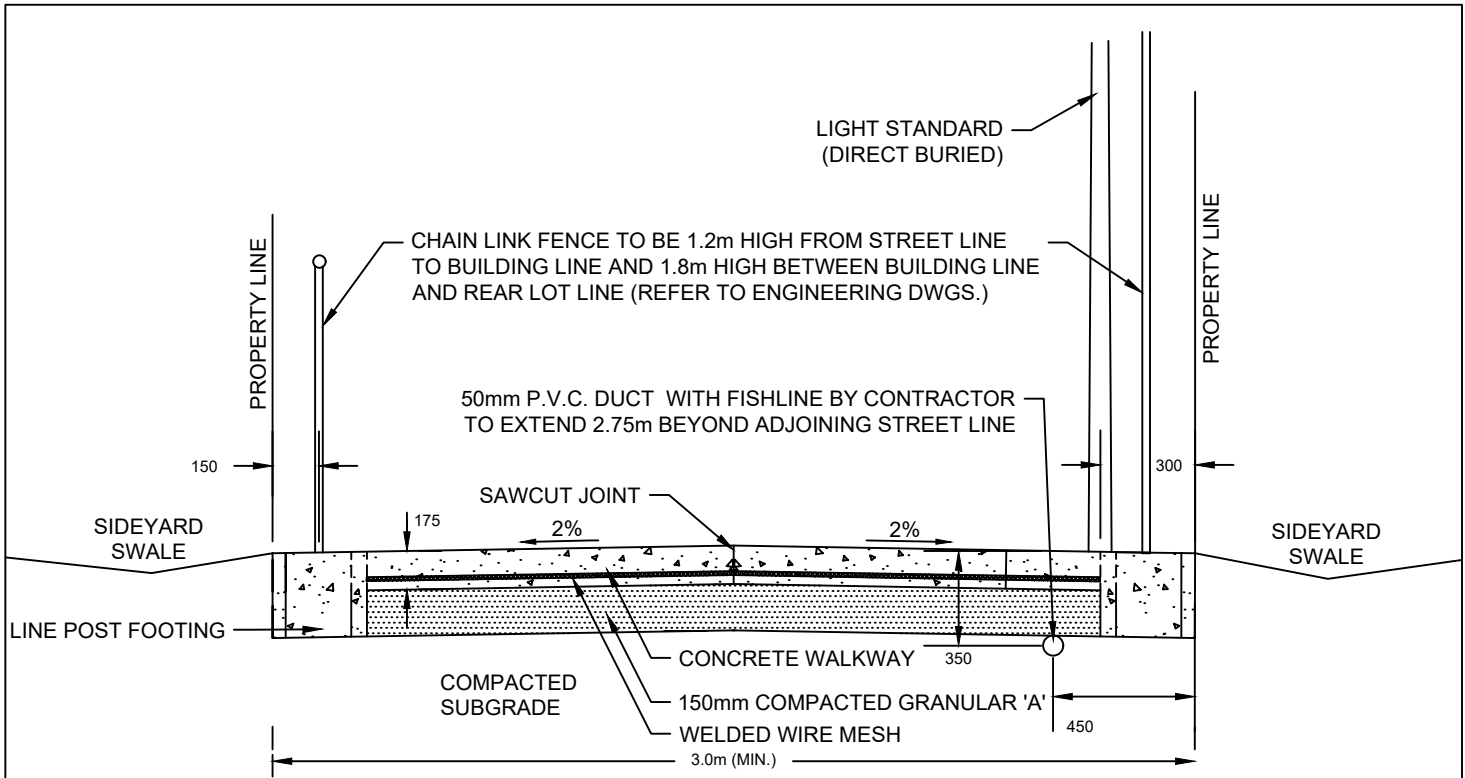

TYPICAL WALKWAY SECTION

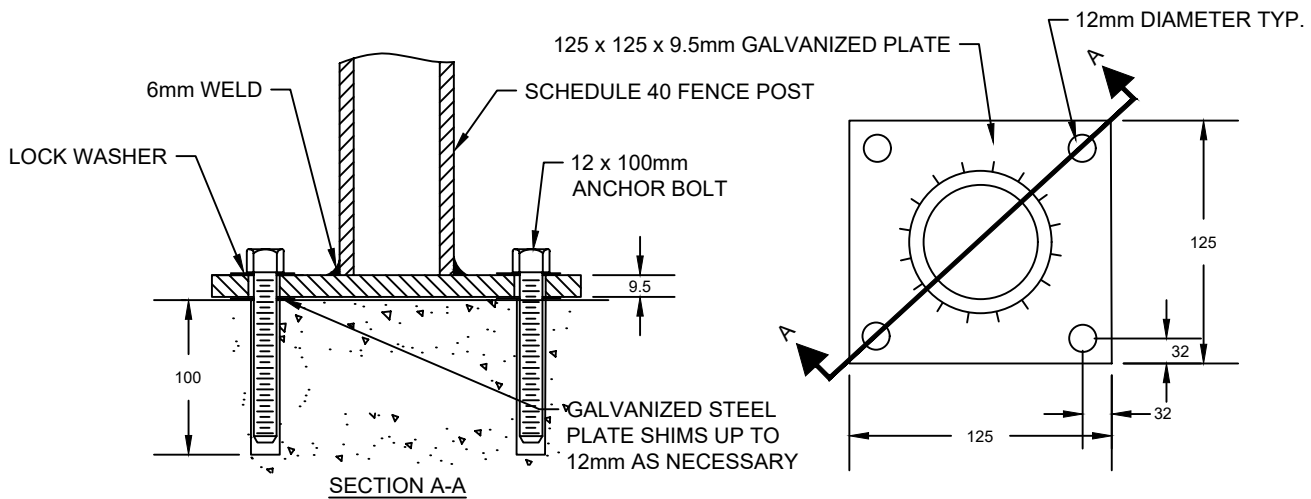

FENCE POST MOUNTING

NOTES

1. REFER TO C-307 AND C-501 FOR ADDITIONAL SIDEWALK / FENCING DETAILS.
2. FENCE MESH TO BE ON WALKWAY SIDE OF POSTS.
3. CONCRETE SHALL CONFORM TO OPSS MUNI 353 AND 1350 SPECIFICATIONS (32MPa, 5.0% - 8.0% AIR).
4. CURING COMPOUND TO BE APPLIED WITHIN HALF HOUR OF FINISHING, ON ALL EXPOSED SURFACES. IF CONCRETE IS INITIALLY CURED WITH OTHER METHODS DUE TO THE WEATHER CONDITIONS, CURING COMPOUND SHALL BE APPLIED WITHIN 24 HOURS OF FINISHING.
5. COLD WEATHER PROTECTION SHALL BE USED WHEN DAY TIME TEMPERATURES ARE EXPECTED TO BE BELOW 5° CELSIUS DURING THE CURING PERIOD AS NOTED IN OPSS MUNI 904.
6. EXPANSION JOINTS TO BE PLACED FULL DEPTH OF WALKWAY AND WHERE WALKWAY ABUTS ANY RIGID STRUCTURE.
7. CONTRACTION JOINTS TO BE SAW-CUT 25% OF FULL DEPTH OF WALKWAY.
8. ALL MATERIAL TO BE GALVANIZED.

ALL DIMENSIONS ARE IN MILLIMETRES UNLESS OTHERWISE NOTED

REVISION NO.: 1
REVISION DATE: DECEMBER 2025



CONCRETE WALKWAY

C-308

0.3m VERTICAL TAPER

REFER TO APPROVED HOUSE SITING PLAN (MAX. 6.0m)

MIN. 1.0m

MIN. 7.5m

PROPERTY LINE

PROPERTY LINE

LIMIT OF APPROACH PAVING

PROPERTY LINE

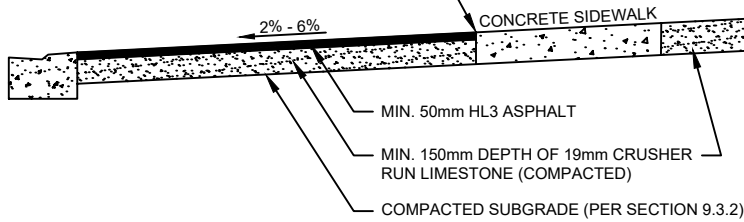

SIDEWALK SIDE OF STREET

PROPERTY LINE

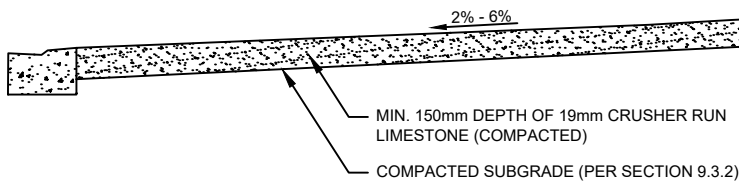

NON-SIDEWALK SIDE OF STREET

ALL DIMENSIONS ARE IN MILLIMETRES UNLESS OTHERWISE NOTED

REVISION NO.: 1

REVISION DATE: DECEMBER 2025



URBAN RESIDENTIAL DRIVEWAY APRON

C-309

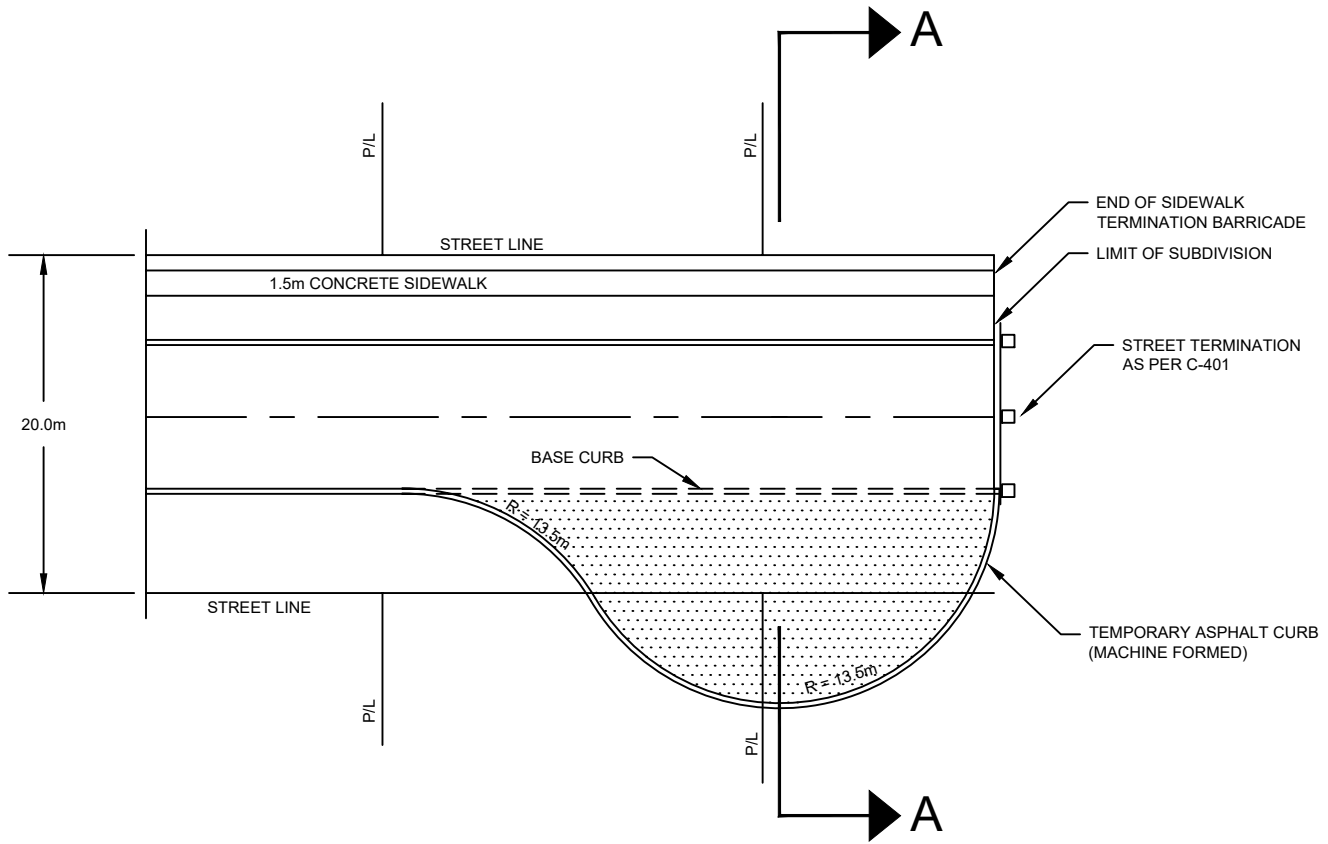

PLAN VIEW

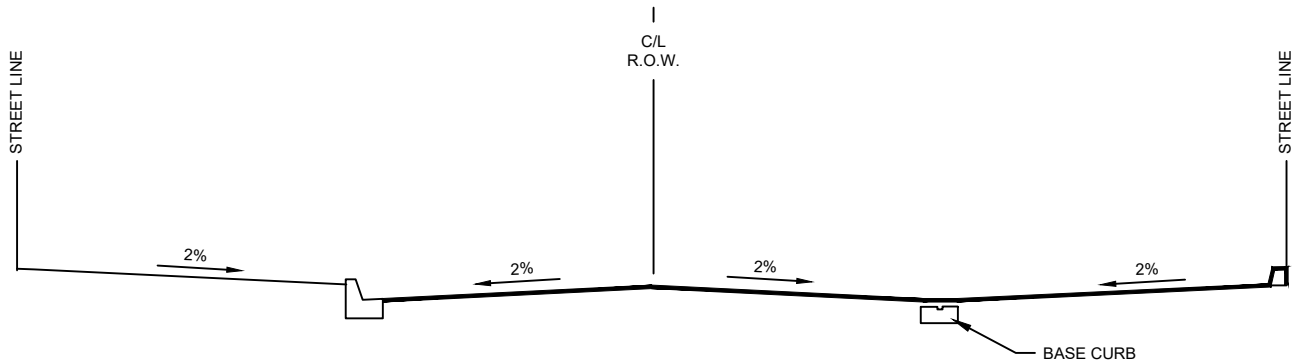

SECTION A-A
PROFILE VIEW

MINIMUM PAVEMENT DESIGN	
SURFACE COURSE ASPHALT (HL3)	40mm
BASE COURSE ASPHALT (HL8)	50mm
GRANULAR 'A'	150mm
GRANULAR 'B'	300mm

ALL DIMENSIONS ARE IN MILLIMETRES UNLESS OTHERWISE NOTED

REVISION NO.: 1
REVISION DATE: DECEMBER 2025



TEMPORARY TURNING CIRCLE

C-310

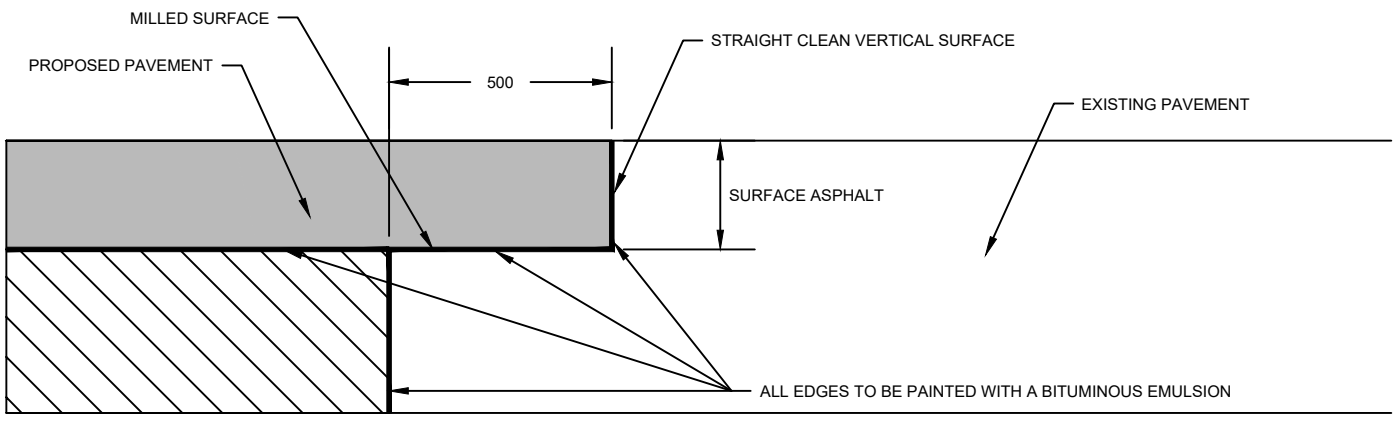
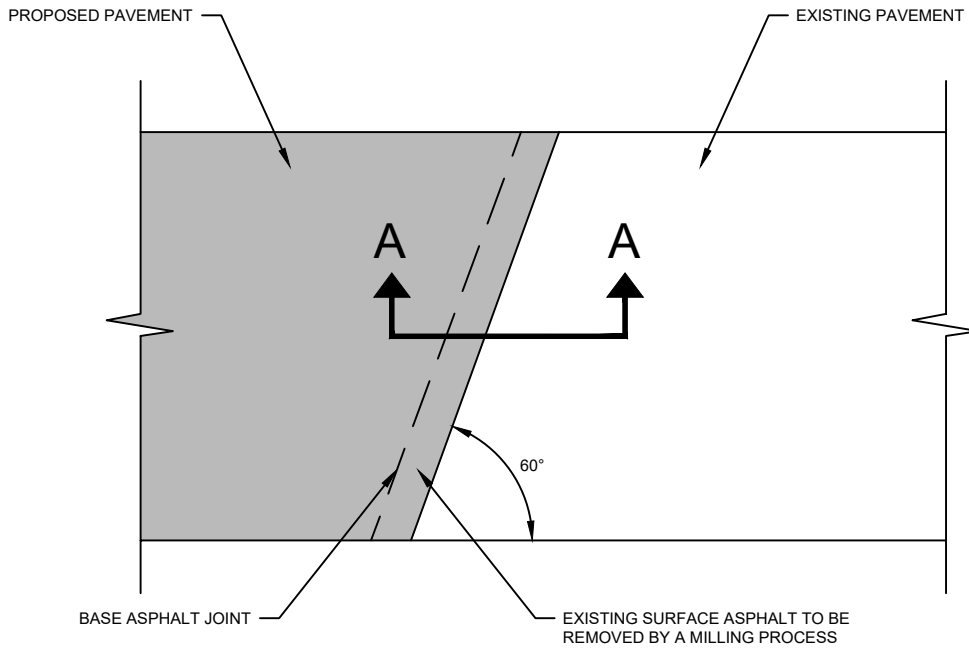

SECTION A-A

ALL DIMENSIONS ARE IN MILLIMETRES UNLESS OTHERWISE NOTED

REVISION NO.: 1
 REVISION DATE: DECEMBER 2025



**SURFACE PAVEMENT
 JOINT TREATMENT**

C-311

ASPHALT MULTI-USE PATH

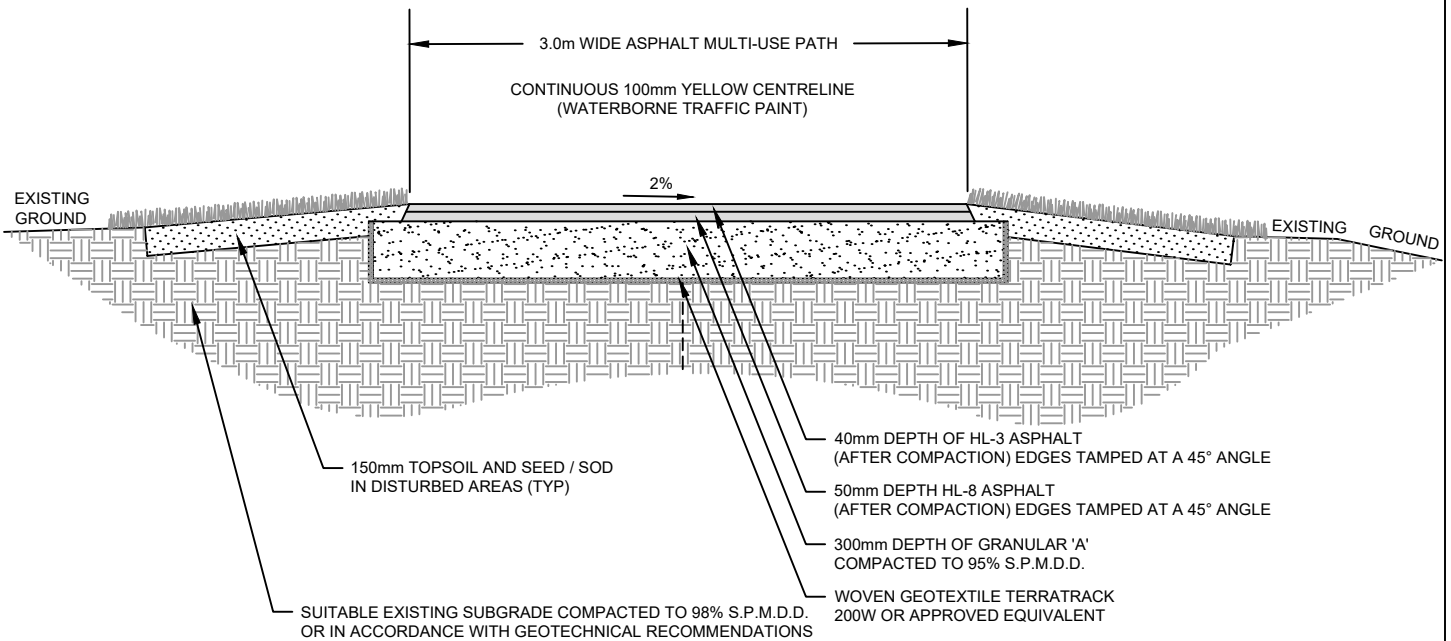

NOTES

1. ASPHALT SURFACE TO BE IN ACCORDANCE WITH OPSS 310 SPECIFICATIONS.
2. GRANULAR BASE MATERIAL SHALL BE IN ACCORDANCE WITH OPSS 1010 SPECIFICATIONS.
3. MULTI-USE PATHWAY TO BE SUPERELEVATED TO ACHIEVE A 2.0% MINIMUM CROSSFALL.

CONCRETE MULTI-USE PATH

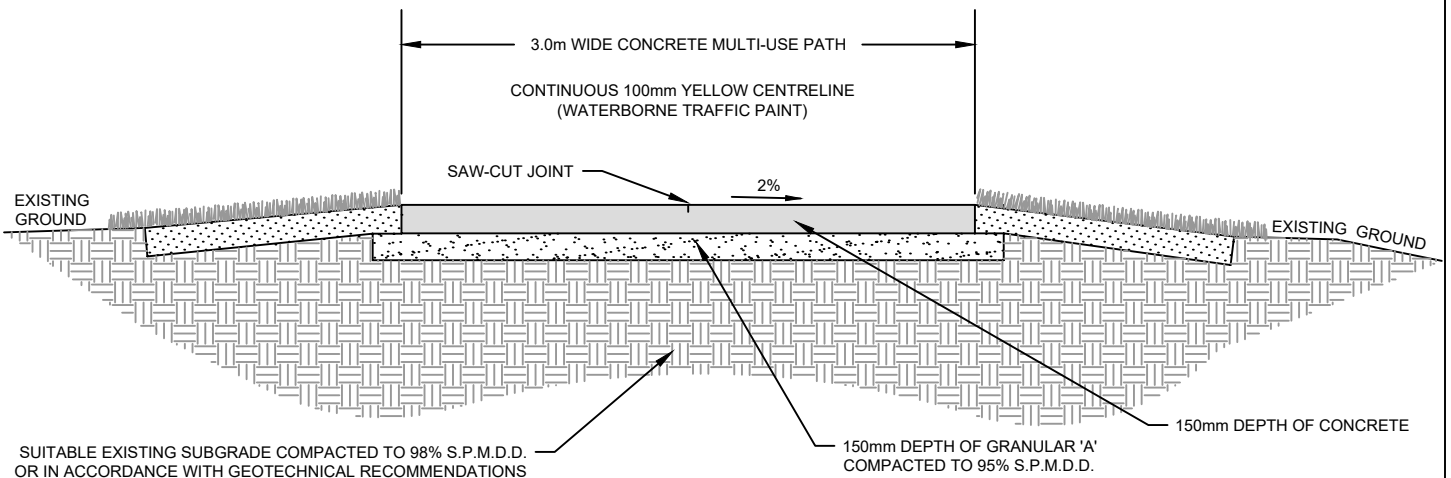

NOTES

1. CONCRETE SHALL CONFORM TO OPSS MUNI 353 AND 1350 SPECIFICATIONS (32MPa, 5.0% - 8.0% AIR)
2. CONTRACTION JOINTS TO BE SAW-CUT TO 25% OF FULL DEPTH OF WALKWAY
3. EXPANSION JOINTS TO BE PLACED FULL DEPTH OF WALKWAY EVERY 15m AND WHERE WALKWAY ABUTS ANY RIGID STRUCTURE
4. GRANULAR BASE MATERIAL SHALL BE IN ACCORDANCE WITH OPSS 1010 SPECIFICATIONS.
5. MULTI-USE PATHWAY TO BE SUPERELEVATED TO ACHIEVE A 2.0% MINIMUM CROSSFALL.

ALL DIMENSIONS ARE IN MILLIMETRES UNLESS OTHERWISE NOTED

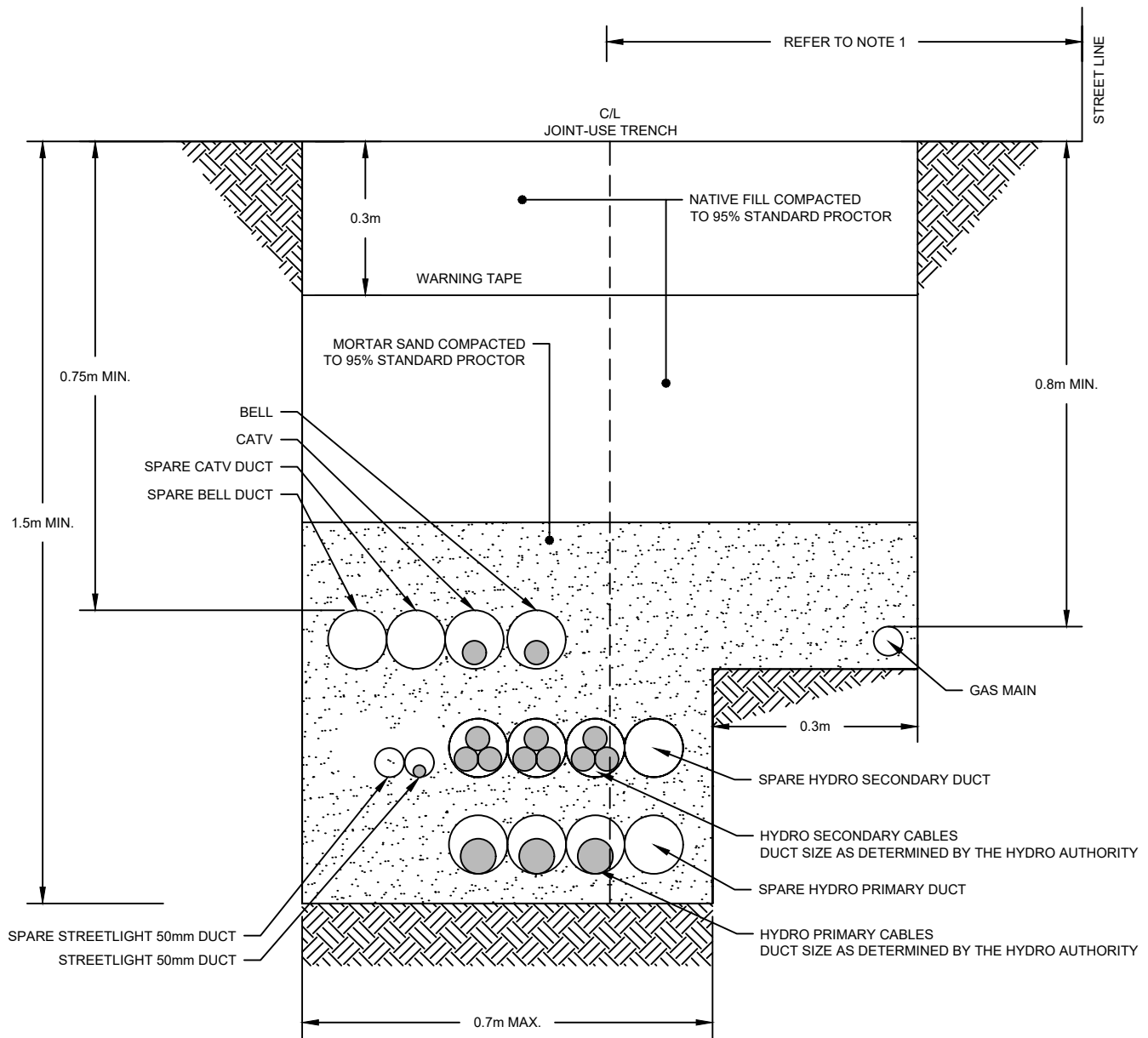

NOTES

1. JOINT-USE TRENCH LOCATION OFFSET FROM STREET LINE REFER TO C-200 THROUGH C-208.
2. MINIMUM DEPTH FOR ROAD CROSSING SHALL BE 1.5m.

ALL DIMENSIONS ARE IN MILLIMETRES UNLESS OTHERWISE NOTED



JOINT-USE TRENCH DETAIL

REVISION NO.: 1
 REVISION DATE: DECEMBER 2025

C-313

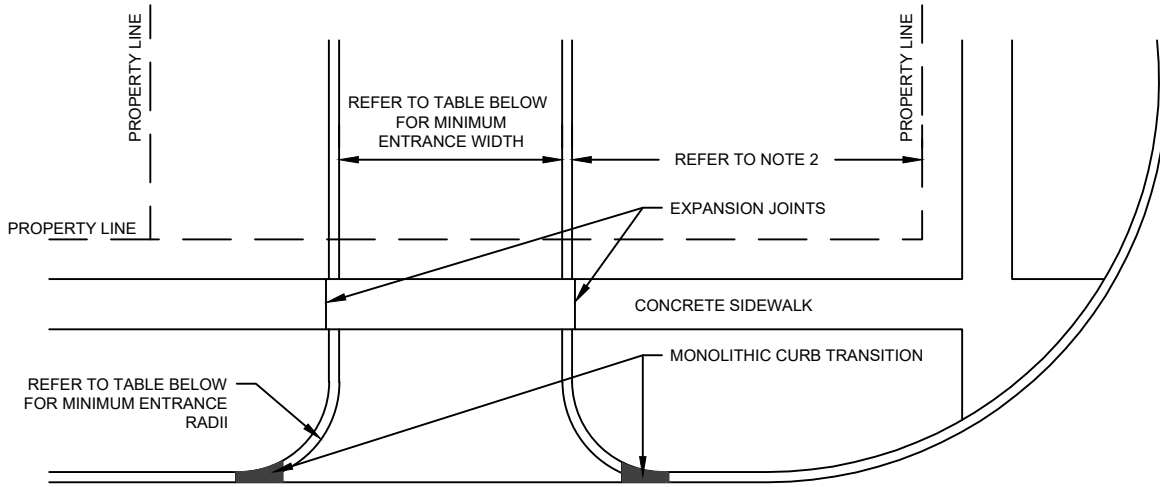

PLAN VIEW

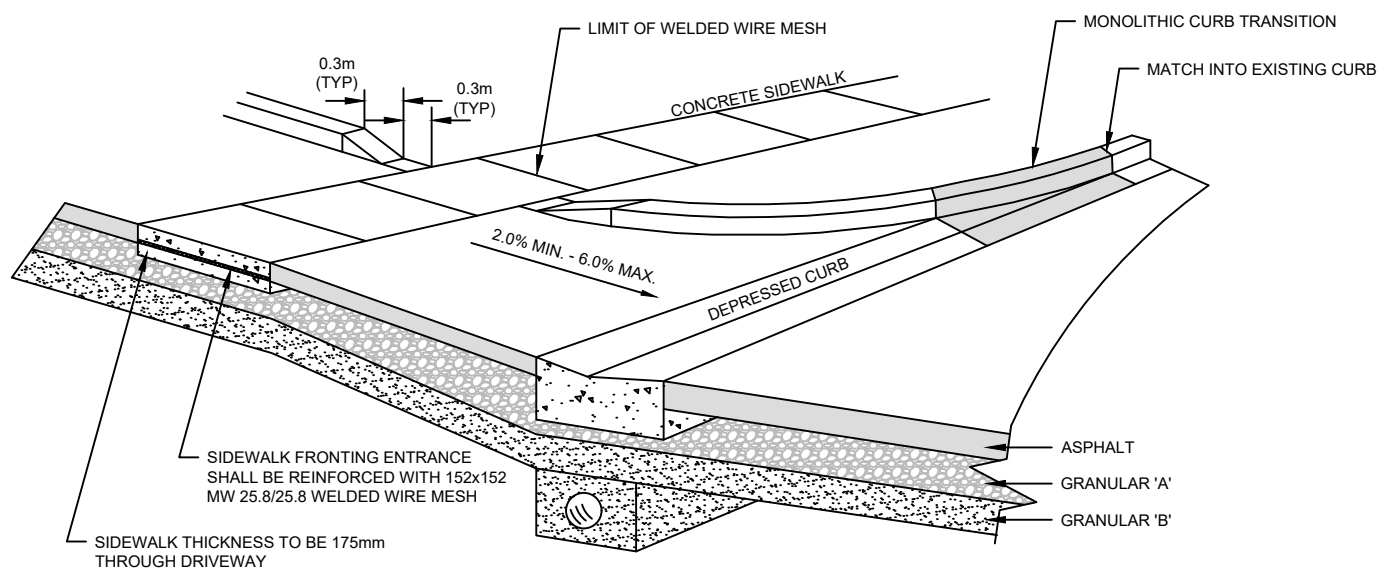

PROFILE VIEW

MINIMUM ENTRANCE DESIGN PARAMETERS		
	COMMERCIAL / INSTITUTIONAL	INDUSTRIAL
SURFACE COURSE ASPHALT (HL3)	40mm	40mm
BASE COURSE ASPHALT (HL8)	50mm	80mm
GRANULAR 'A'	150mm	150mm
GRANULAR 'B'	300mm	375mm
ENTRANCE WIDTH (MIN.)	6.0m	6.0m
ENTRANCE RADIUS (MIN.)	6.0m	9.0m

NOTES

1. ALL ENTRANCES MUST BE ALIGNED PERPENDICULAR TO THE ROAD, SKEWED ENTRANCES ARE NOT PERMITTED.
2. ENTRANCES SHALL NOT BE LOCATED CLOSER THAN 7.5m FROM THE NEAR STREET LINE AT INTERSECTIONS.
3. FOR SIDEWALK CONSTRUCTION DETAILS, REFER TO C-307

ALL DIMENSIONS ARE IN MILLIMETRES UNLESS OTHERWISE NOTED



COMMERCIAL / INSTITUTIONAL & INDUSTRIAL ENTRANCE DETAILS

REVISION NO.: 1
REVISION DATE: DECEMBER 2025

C-314

ASPHALT DAMAGE

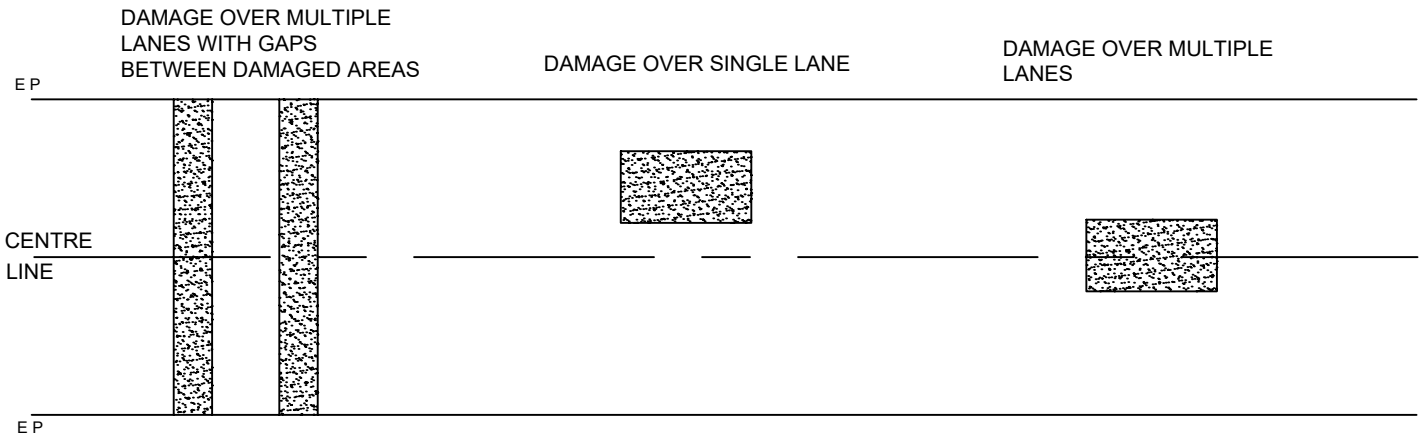

ACCEPTABLE REPAIR

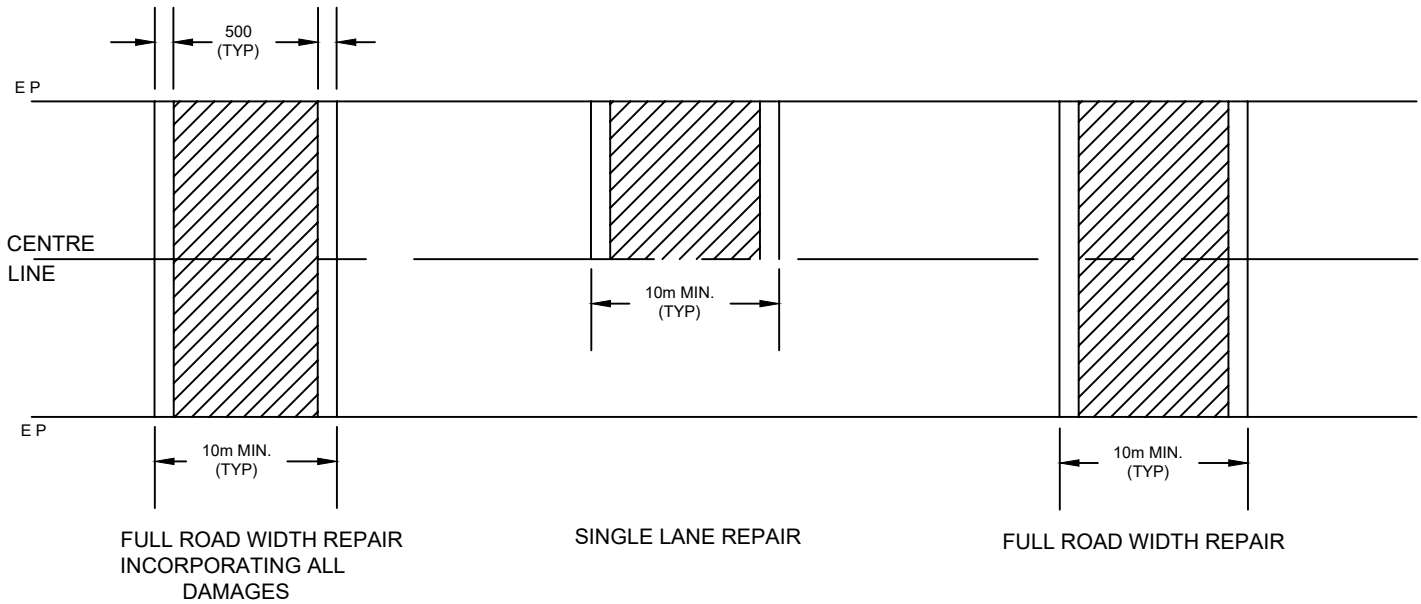

NOTES

1. THIS DRAWING SHALL BE READ IN CONJUNCTION WITH C-311 SURFACE JOINT TREATMENT
2. EXISTING ROADS SHALL BE SAW CUT PRIOR TO ANY WORK OR EXCAVATION AND A TRENCH BOX USED TO MINIMIZE THE WITH OF DISTURBANCE.
3. ALL REPAIRS ARE TO EXTEND A MINIMUM 0.5m BEYOND THE EDGE OF THE REPAIR OR FULL DEPTH REMOVAL, AS NOTED IN C-311
4. ALL VERTICAL FACES OF END JOINTS SHALL BE SWEEP CLEAN AND PAINTED WITH A BITUMINOUS EMULSION PRIOR TO PLACING ASPHALT.

ALL DIMENSIONS ARE IN MILLIMETRES UNLESS OTHERWISE NOTED



ASPHALT RESTORATION
AREA

REVISION NO.: 1
REVISION DATE: DECEMBER 2025

C-315

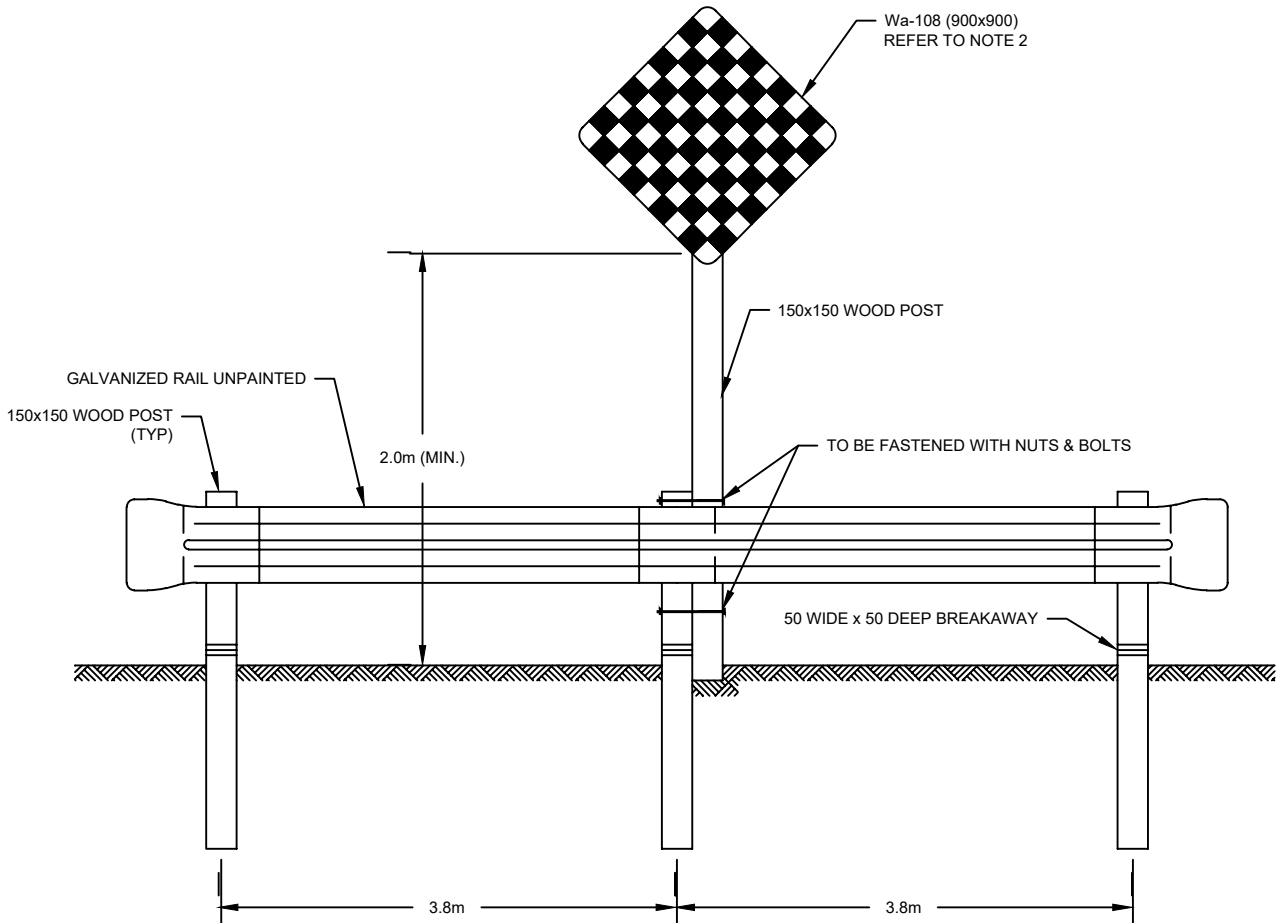

BARRICADE DETAIL

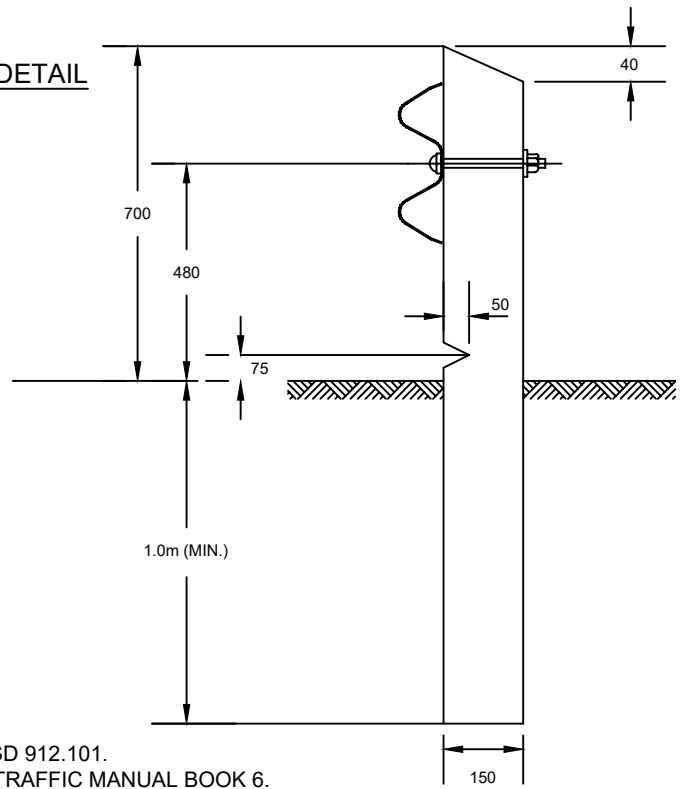

POST DETAIL

NOTES

1. THIS STANDARD IS TO BE READ IN CONJUNCTION WITH OPSD 912.101.
2. CHECKERBOARD SIGN (Wa-108) AS SPECIFIED IN ONTARIO TRAFFIC MANUAL BOOK 6.
3. ALL HARDWARE TO BE GALVANIZED.
4. ALL WOOD MEMBERS ARE TO BE PRESSURE TREATED.
5. POSTS ARE TO BE DIRECT BURIED

ALL DIMENSIONS ARE IN MILLIMETRES UNLESS OTHERWISE NOTED



**STREET TERMINATION DETAIL
(NON-ASPHALT APPLICATION)**

REVISION NO.: 1
REVISION DATE: DECEMBER 2025

C-401

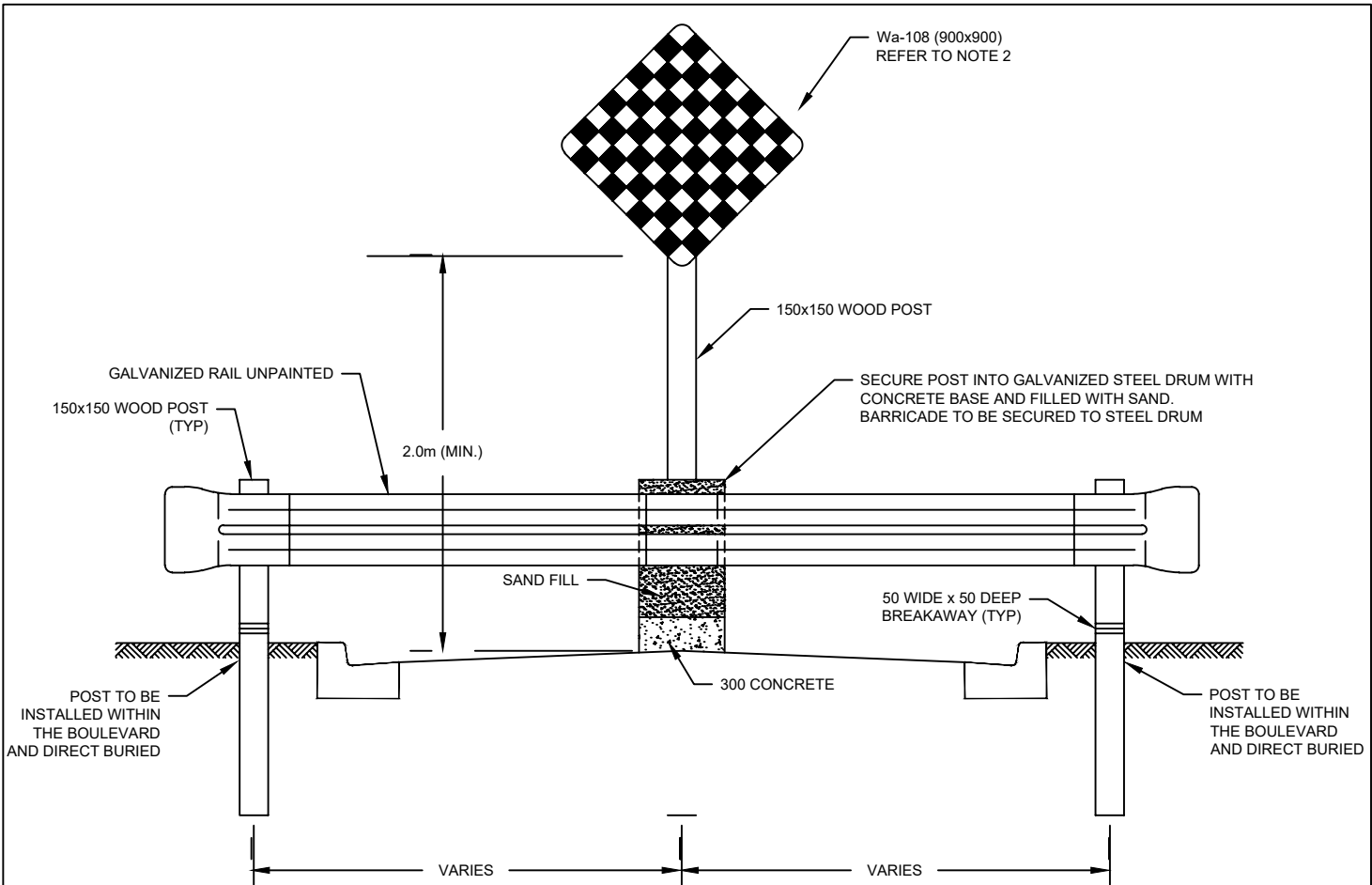

BARRICADE DETAIL

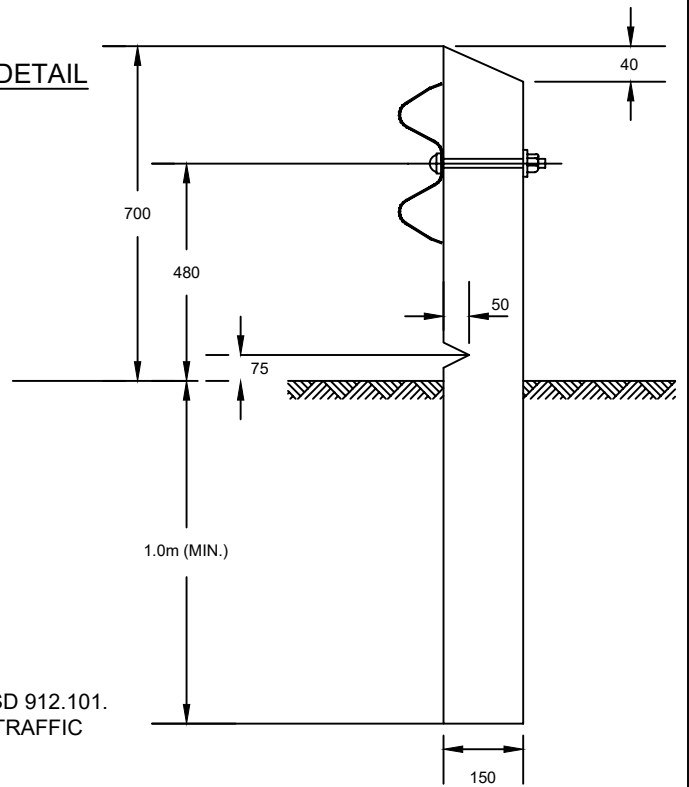

POST DETAIL

NOTES

1. THIS STANDARD IS TO BE READ IN CONJUNCTION WITH OPSD 912.101.
2. CHECKERBOARD SIGN (Wa-108) AS SPECIFIED IN ONTARIO TRAFFIC MANUAL BOOK 6.
3. ALL HARDWARE TO BE GALVANIZED.
4. ALL WOOD MEMBERS ARE TO BE PRESSURE TREATED.

ALL DIMENSIONS ARE IN MILLIMETRES UNLESS OTHERWISE NOTED



**STREET TERMINATION DETAIL
(ASPHALT APPLICATION)**

REVISION NO.: 1
REVISION DATE: DECEMBER 2025

C-401B

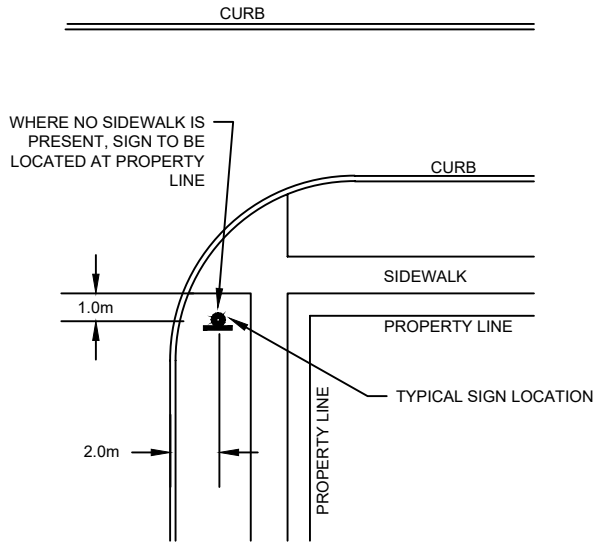

STREET SIGN LOCATION DETAIL

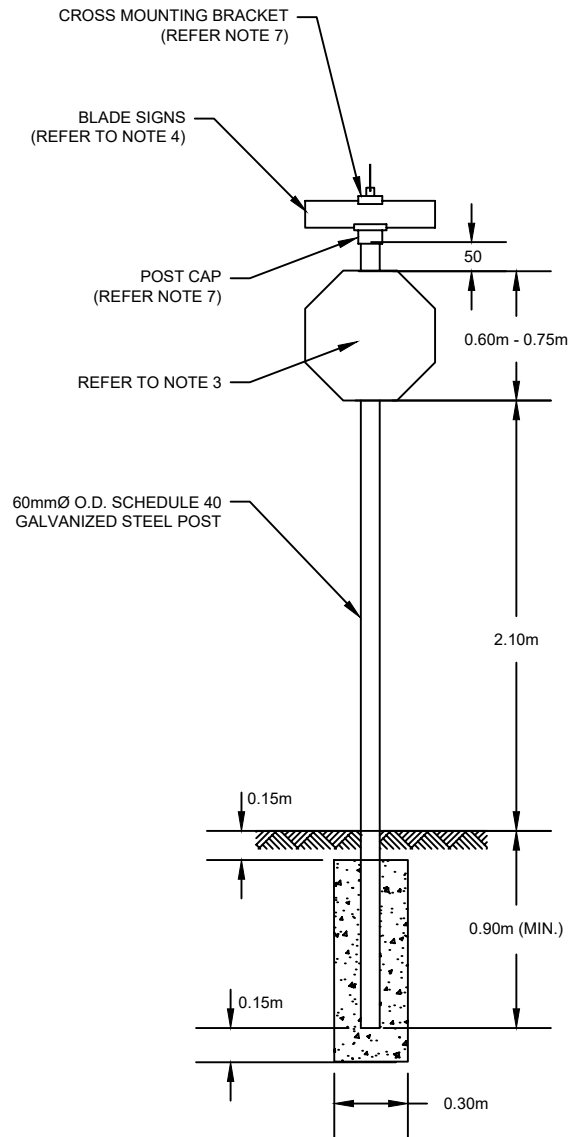

STREET SIGN DETAIL

NOTES

1. SIGN MATERIAL BLANKS AND REFLECTIVE SHEETING MUST MEET OR EXCEED CURRENT MINISTRY OF TRANSPORTATION ONTARIO SPECIFICATIONS.
2. A SCHEDULE OF SIGNS MUST BE APPROVED BY THE MUNICIPALITY BEFORE ANY ORDER IS PLACED.
3. Ra-1 SIGNAGE (600mm X 600mm) TO BE USED ON LOCAL ROADS AND Ra-1 (750mm X 750mm) ON COLLECTOR OR HIGHER CLASS ROADS.
4. STREET SIGNS AT ALL PUBLIC ROAD JUNCTIONS TO BE 150mm (6 IN.) WITH WHITE LETTERING ON GREEN SHEETING, REFER TO C-402B FOR DETAILS. FOR PRIVATE STREET SIGNS REFER TO C-402B.
5. WHERE NO CURB AND GUTTER EXISTS, OFFSET IS TO BE MEASURED FROM EDGE OF PAVEMENT.
6. ALL POST MOUNTED SIGNS ARE TO BE SECURED BY APPROVED ALUMINUM EXTRUSION BRACKETS. WHERE PERMITTED, SIGNS MAY BE MOUNTED ON UTILITY POLES USING APPROVED STAINLESS STEEL HARDWARE.
7. FOR BLADES 700mm (28 IN.) AND UNDER USE 125mm (5 IN.) POST CAP AND CROSS MOUNTING BRACKETS. FOR LONGER BLADES USE 300mm (12 IN.) POST CAP AND CROSS MOUNTING BRACKETS. WHERE NO NAME BLADES ARE PRESENT, POST CAP REQUIRED ON STEEL POST
8. GALVANIZED 25mm WASHERS TO BE USED ON FACE OF EACH SIGN. NON-METALLIC WASHERS ARE NOT PERMITTED.
9. STREET SIGN LOCATION FOR URBAN AREAS IS SHOWN ABOVE. RURAL STREET SIGN LOCATIONS SHALL BE IN CONFORMANCE WITH ONTARIO TRAFFIC MANUAL BOOK 5, SECTION 2.
10. CONTACT MUNICIPALITY FOR MORE SPECIFICATIONS IF REQUIRED ON SPECIALITY SIGNS.
11. THIS DETAIL APPLIES TO ALL OTHER SIGNAGE, UNLESS APPROVED OTHERWISE.



STREET SIGN DETAIL

REVISION NO.: 1
REVISION DATE: DECEMBER 2025

C-402

PRIVATE ROAD SIGN DETAIL



NOTES:

1. BLADES TO BE 200mm (8 IN.) ALUMINUM EXTRUSION ALLOY
2. SIGN BLADE SHALL ACCOMMODATE 100mm (4 IN.) LETTERS FOR STREET NAME WITH 45mm (1 ¾ IN.) LETTERING TO STATE PRIVATE ROAD.
2. BLADE LENGTH TO BE DETERMINED BY STREET NAME, WITH MIN. 400mm (16 IN.) AND MAX. 1050mm (42 IN.)
3. REFLECTIVE FINISH TO BE 3M OR EQUIVALENT PER MTO SPECIFICATIONS ENGINEER GRADE BLUE.
5. LETTERING FONT TO BE 100 mm (4 IN.) SERIES C LEGEND, HIGHWAY GOTHIC C, 3M SCOTCHLITE SILVER / WHITE ENGINEER GRADE DIE CUT OVERLAY LETTERS, ALL UPPERCASE.
6. IN THE EVENT OF A LONGER STREET NAME, MAXIMUM BLADE LENGTH IS 1050mm (42 IN.) FONT WIDTH TO BE REDUCED GRADUALLY AS NECESSARY TO FIT. ALL ADJUSTMENTS TO BE REVIEWED AND APPROVED BY THE MUNICIPALITY PRIOR TO IMPLEMENTATION
7. ALL INTERSECTIONS OF PUBLIC ROADS WITH PRIVATE ROADS SHALL BE SIGNED USING A COMBINATION OF STANDARD GREEN SIGNS FOR PUBLIC ROADS AND BLUE SIGNS FOR PRIVATE ROADS, AS SPECIFIED.

PUBLIC ROAD SIGN DETAIL

POPPY SYMBOL:

1. SYMBOL SHALL BE RED 3M SCOTCHLITE ENGINEER GRADE REFLECTIVE SHEETING, 100mm (4 IN.) WIDE AND 100mm (4 IN.) HIGH.
2. SYMBOL SHALL BE PLACED 25mm (1IN.) FROM THE LEFT EDGE OF THE BLADE AND CENTERED FROM TOP AND BOTTOM. STREET NAME TO FOLLOW 25mm (1 IN.) FROM THE POPPY SYMBOL.

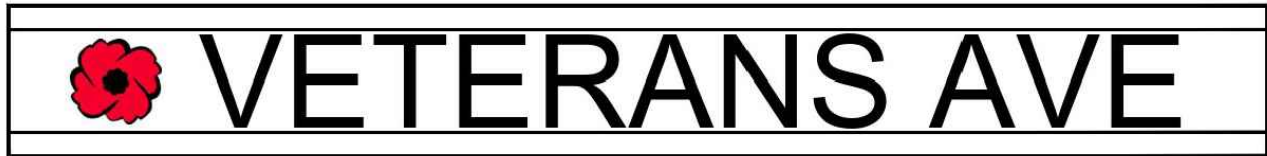

NOTES:

1. STREET SIGNS AT ALL PUBLIC ROAD JUNCTIONS TO BE 150mm WITH WHITE LETTERING ON GREEN SHEETING.
2. BLADE LENGTH TO BE DETERMINED BY STREET NAME, WITH MIN. 400mm (16 IN.) AND MAX. 1050mm (42 IN.).
3. REFLECTIVE FINISH TO BE 3M ENGINEER GRADE GREEN.
4. LETTERING FONT TO BE 100mm (4 IN.) HIGHWAY GOTHIC C, 3M SCOTCHLITE SILVER / WHITE ENGINEER GRADE DIE CUT OVERLAY LETTERS, ALL UPPERCASE.
5. IN THE EVENT OF A LONGER STREET NAME, MAXIMUM BLADE LENGTH IS 1050mm (42 IN.). FONT WIDTH TO BE REDUCED GRADUALLY AS NECESSARY TO FIT. ALL ADJUSTMENTS TO BE REVIEWED AND APPROVED BY THE MUNICIPALITY PRIOR TO IMPLEMENTATION

	<p style="font-size: 1.2em; margin: 0;">SPECIALIZED STREET SIGN DETAIL</p>	REVISION NO.: 1
		REVISION DATE: DECEMBER 2025
		C-402B

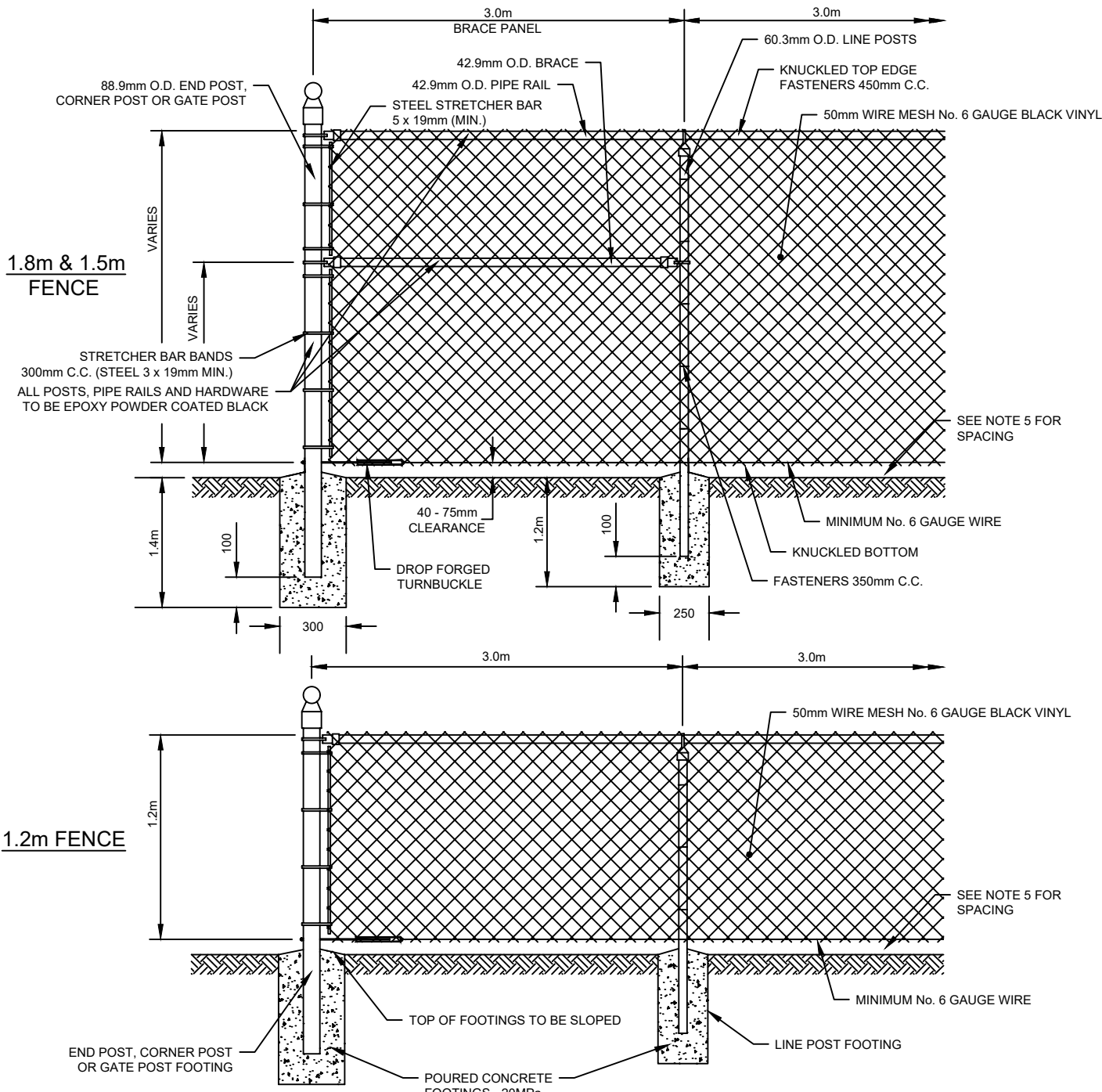

NOTES

1. ALL POSTS, PIPE RAILS, AND HARDWARE TO BE EPOXY POWDER COATED BLACK.
2. WIRE MESH TO BE ON THE PUBLIC SIDE OF THE FENCE WITH THE POSTS AND RAILS ON THE PRIVATE SIDE.
3. FASTENERS SHALL BE 6 GAUGE ALUMINUM OR HEAVIER, EPOXY POWDER COATED BLACK. ALL RAILS AND POSTS GAUGE TO BE SCHEDULE 40.
4. SONOTUBES ARE TO BE USED FOR ALL FOOTINGS.
5. BOTTOM WIRE TO BE 'WOVEN' THROUGH MESH TO SECURE MESH. WIRE TO BE 'WOVEN' THROUGH MESH APPROXIMATELY EVERY 300mm.
6. MAXIMUM 50mm GAP FROM CHAIN LINK FENCE TO GRADE BENEATH.

ALL DIMENSIONS ARE IN MILLIMETRES UNLESS OTHERWISE NOTED



1.8m / 1.5m / 1.2m BLACK VINYL CHAIN LINK FENCE

REVISION NO.: 1
REVISION DATE: DECEMBER 2025

C-501

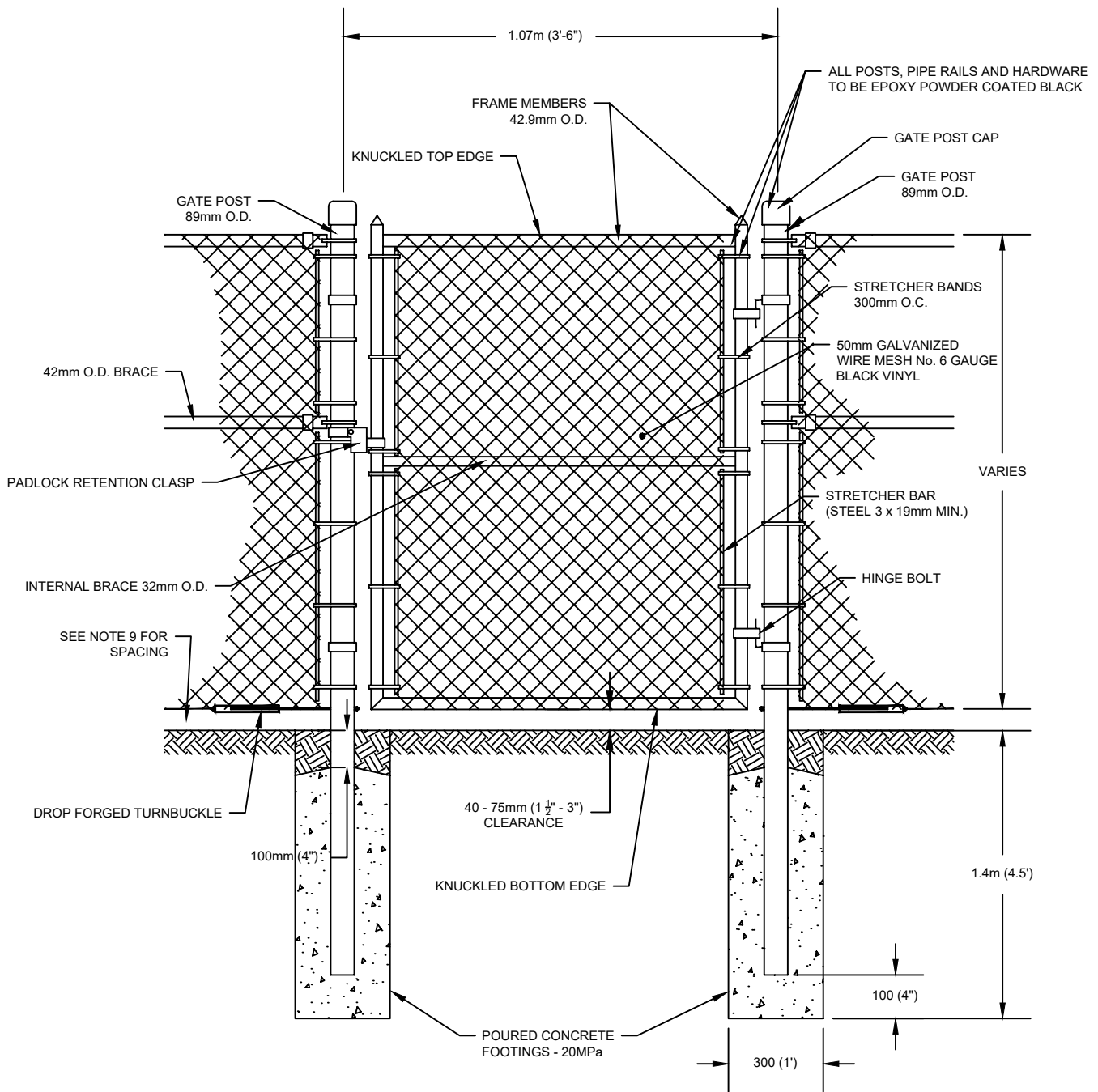

NOTES

1. STANDARD TO BE READ IN CONJUNCTION WITH C-501..
2. WIRE MESH TO BE ON PUBLIC SIDE OF GATE.
3. GATE FRAME TO BE CONSTRUCTED OF 42.8mm O.D. STEEL PIPE, EPOXY POWDER COATED BLACK.
4. GATE TO OPEN ONTO PRIVATE PROPERTY.
5. ALL GATE COMPONENTS TO BE GALVANIZED SCHEDULE 40, EPOXY POWDER COATED BLACK.
6. ALL WIRE FASTENERS TO BE 6 GAUGE ALUMINUM, EPOXY POWDER COATED BLACK.
7. GATE POSTS ARE TO BE 3.0m IN LENGTH.
8. SONOTUBES ARE TO BE USED FOR ALL FOOTINGS.
9. MAXIMUM 50mm GAP FROM CHAIN LINK FENCE TO GRADE BENEATH.

ALL DIMENSIONS ARE IN MILLIMETRES UNLESS OTHERWISE NOTED

REVISION NO.: 1
 REVISION DATE: DECEMBER 2025



**BLACK VINYL CHAIN LINK
 SINGLE GATE (RESIDENTIAL)**

C-502

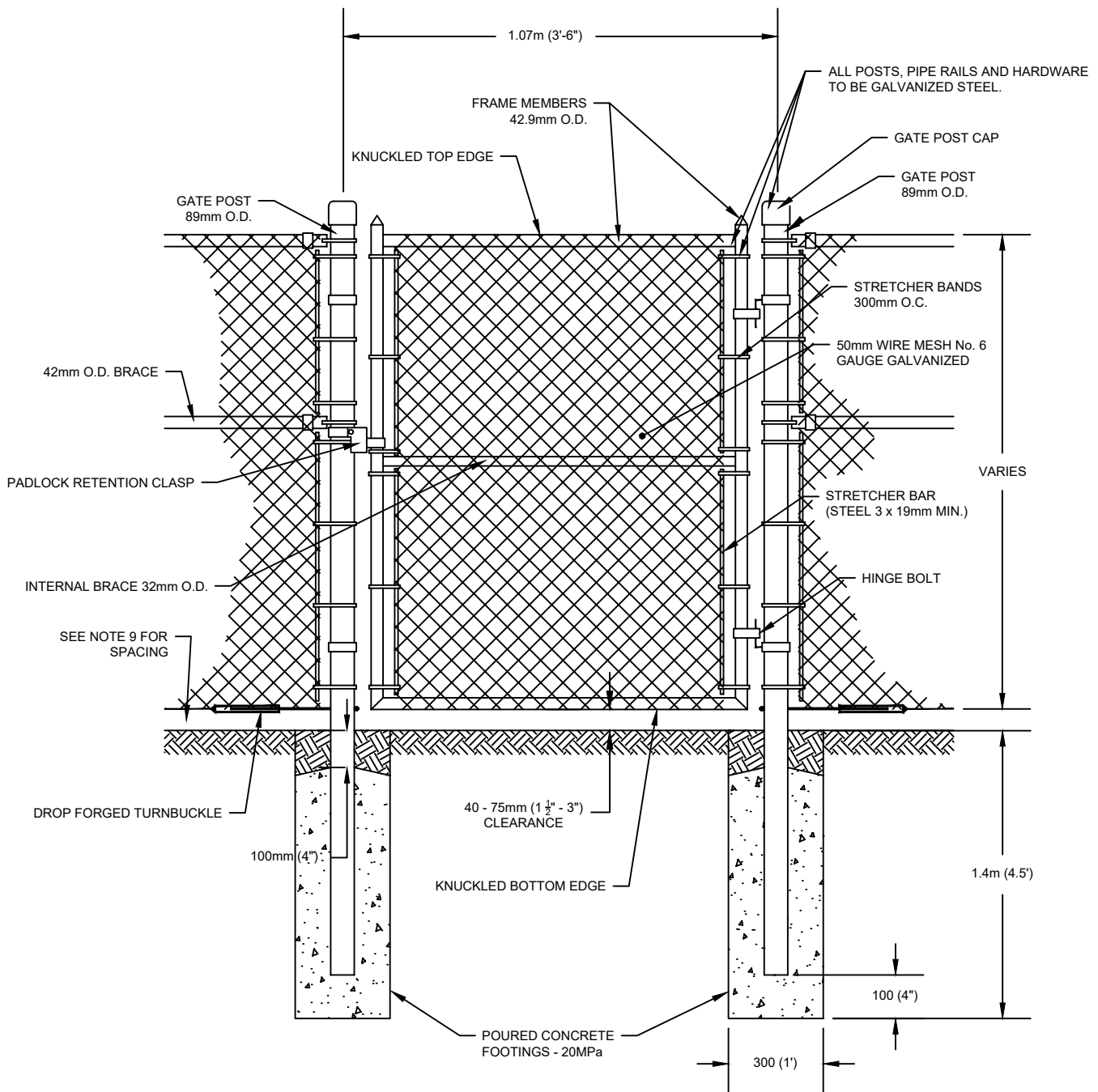

NOTES

1. STANDARD TO BE READ IN CONJUNCTION WITH C-501..
2. WIRE MESH TO BE ON PUBLIC SIDE OF GATE.
3. GATE FRAME TO BE CONSTRUCTED OF 42.8mm O.D. STEEL PIPE, GALVANIZED STEEL.
4. GATE TO OPEN ONTO PRIVATE PROPERTY.
5. ALL GATE COMPONENTS TO BE GALVANIZED SCHEDULE 40.
6. ALL WIRE FASTENERS TO BE 6 GAUGE ALUMINUM, OR HEAVIER.
7. GATE POSTS ARE TO BE 3.0m IN LENGTH.
8. SONOTUBES ARE TO BE USED FOR ALL FOOTINGS.
9. MAXIMUM 50mm GAP FROM CHAIN LINK FENCE TO GRADE BENEATH.

ALL DIMENSIONS ARE IN MILLIMETRES UNLESS OTHERWISE NOTED



**GALVANIZED STEEL CHAIN LINK
SINGLE GATE (RESIDENTIAL)**

REVISION NO.: 1
REVISION DATE: DECEMBER 2025

C-502B

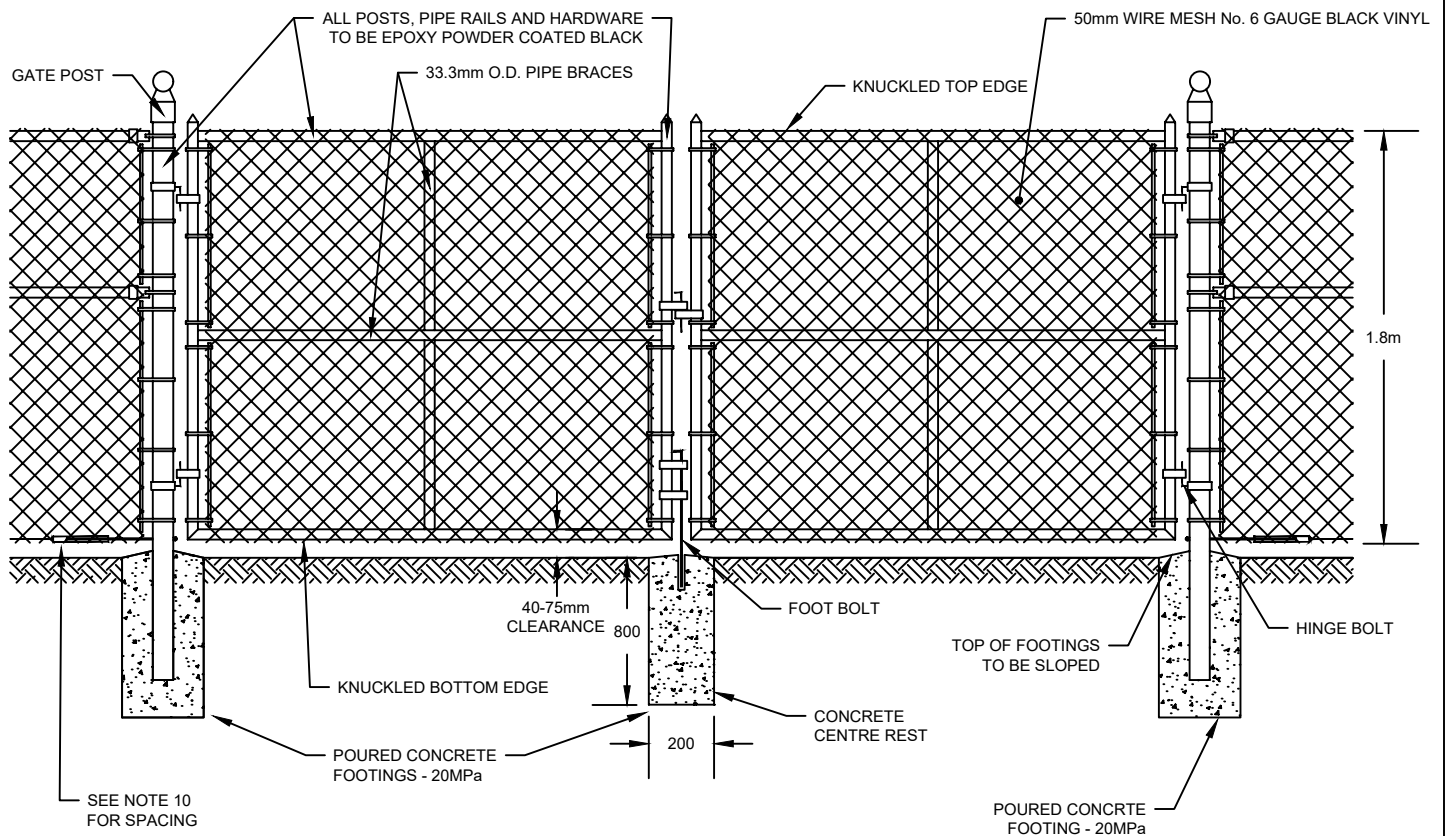

NOTES

1. THIS STANDARD TO BE READ IN CONJUNCTION WITH C-501.
2. WIRE MESH TO BE ON PUBLIC SIDE OF GATE.
3. GATE FRAME TO BE CONSTRUCTED OF 42.8mm O.D. STEEL PIPE, EPOXY POWDER COATED BLACK.
4. GATE TO OPEN ONTO PRIVATE PROPERTY.
5. ALL HARDWARE AND GATE FRAME TO BE GALVANIZED SCHEDULE 40, EPOXY POWDER COATED BLACK.
6. ALL WIRE FASTENERS TO BE 6 GAUGE ALUMINUM, EPOXY POWDER COATED BLACK.
7. FRAME MEMBERS AND BRACES ARE TO BE WELDED.
8. GATE POSTS ARE TO BE 3.0m IN LENGTH.
9. SONOTUBES ARE TO BE USED FOR ALL FOOTINGS.
10. MAXIMUM 50mm GAP FROM CHAIN LINK FENCE TO GRADE BENEATH

ALL DIMENSIONS ARE IN MILLIMETRES UNLESS OTHERWISE NOTED



**BLACK VINYL CHAIN LINK
DOUBLE GATE**

REVISION NO.: 1
REVISION DATE: DECEMBER 2025

C-503

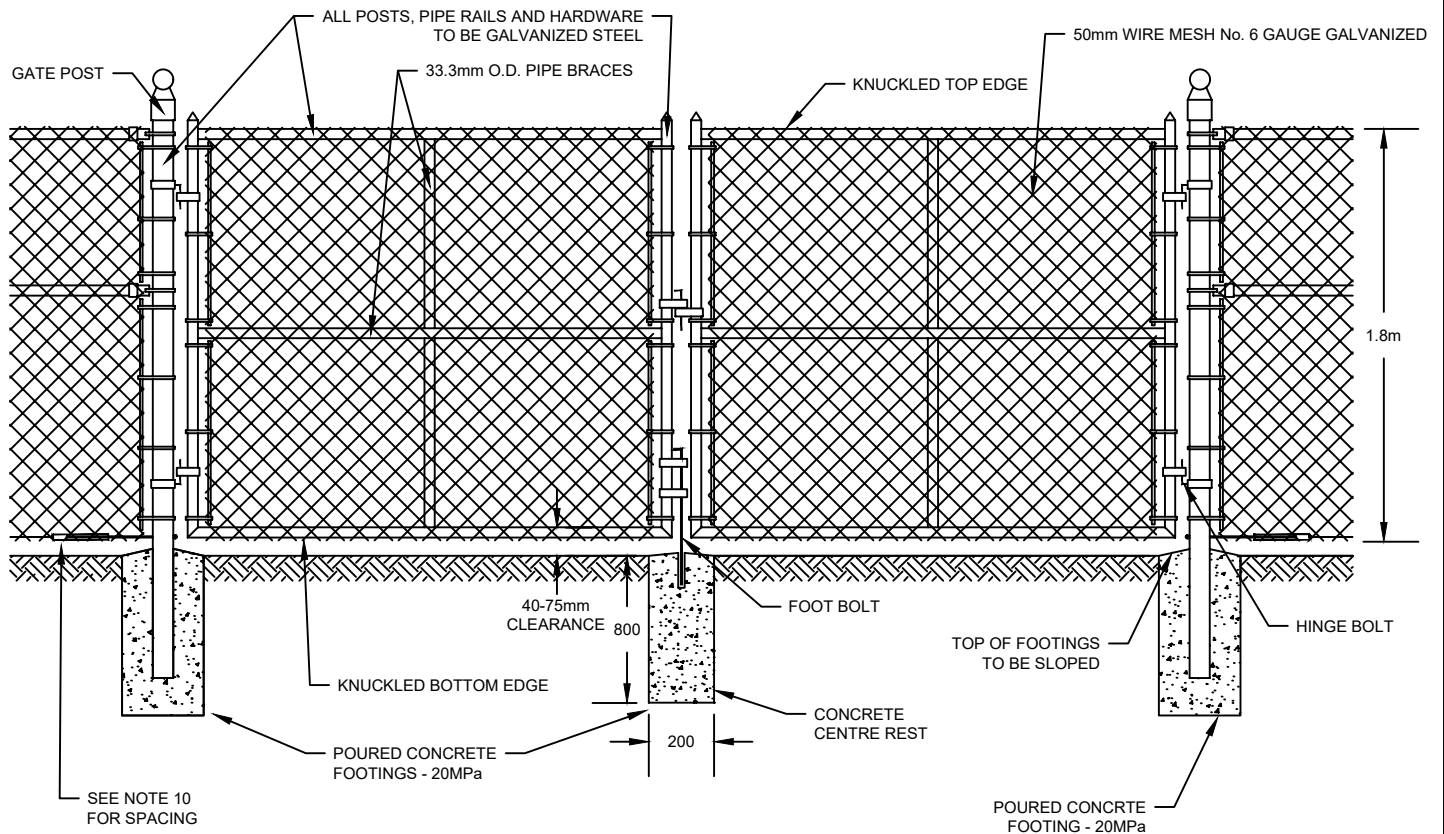

NOTES

1. THIS STANDARD TO BE READ IN CONJUNCTION WITH C-501.
2. WIRE MESH TO BE ON PUBLIC SIDE OF GATE.
3. GATE FRAME TO BE CONSTRUCTED OF 42.8mm O.D. GALVANIZED STEEL PIPE.
4. GATE TO OPEN ONTO PRIVATE PROPERTY.
5. ALL HARDWARE AND GATE FRAME TO BE GALVANIZED SCHEDULE 40.
6. ALL WIRE FASTENERS TO BE 6 GAUGE ALUMINUM, OR HEAVIER
7. FRAME MEMBERS AND BRACES ARE TO BE WELDED.
8. GATE POSTS ARE TO BE 3.0m IN LENGTH.
9. SONOTUBES ARE TO BE USED FOR ALL FOOTINGS.
10. MAXIMUM 50mm GAP FROM CHAIN LINK FENCE TO GRADE BENEATH

ALL DIMENSIONS ARE IN MILLIMETRES UNLESS OTHERWISE NOTED



**GALVANIZED STEEL CHAIN LINK
DOUBLE GATE**

REVISION NO.: 1

REVISION DATE: DECEMBER 2025

C-503B

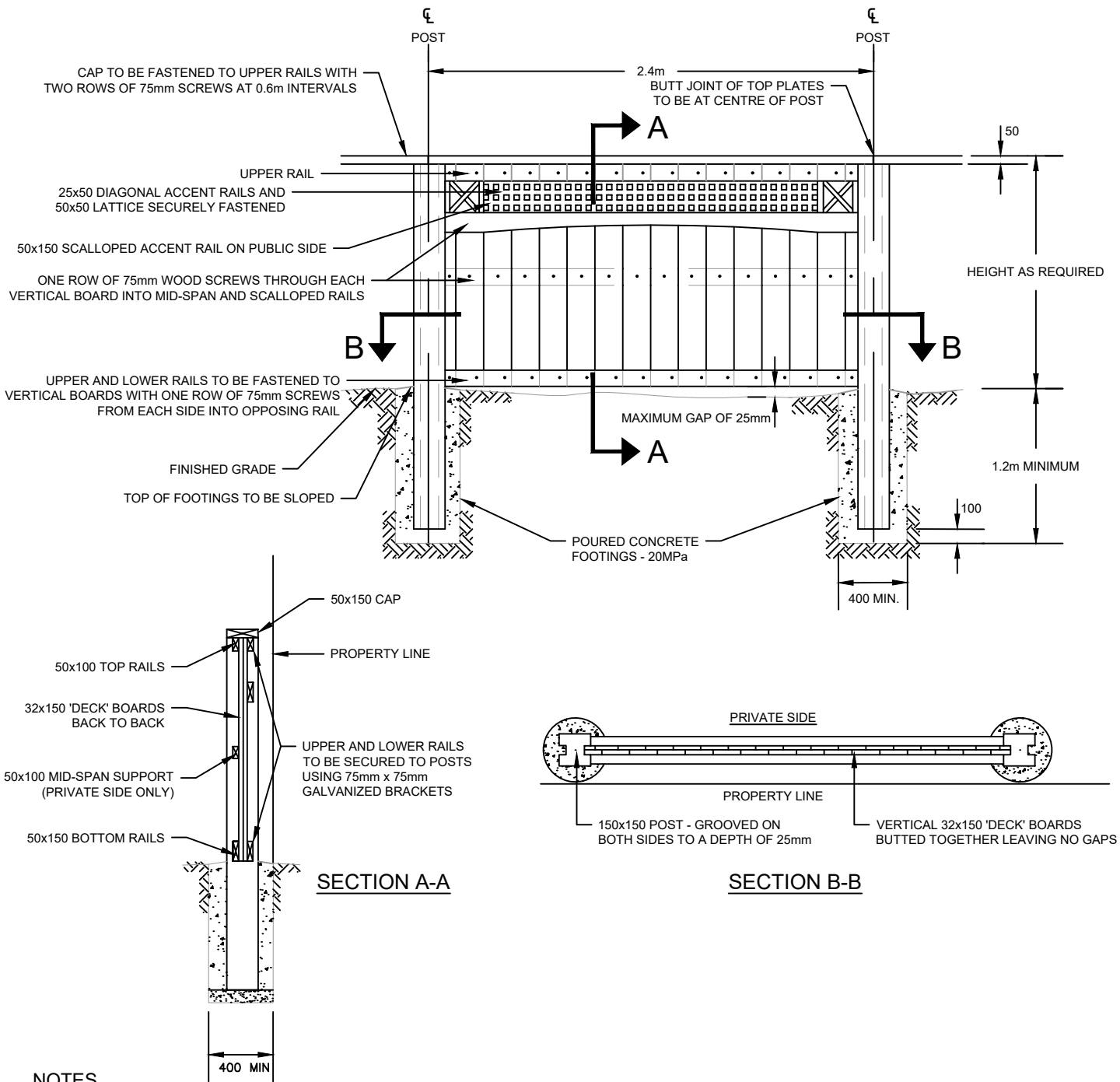

NOTES

1. ENGINEER TO VERIFY DESIGN STANDARD MEETS FENCE DENSITY / HEIGHT OF NOISE ATTENUATION REPORT.
2. FENCE, INCLUDING FOOTING, TO BE LOCATED ENTIRELY ON PRIVATE PROPERTY.
3. FENCES EXCEEDING 1.8m IN HEIGHT REQUIRE STAMPED DRAWINGS FROM A STRUCTURAL ENGINEER AND APPROVAL FROM A LICENSED ARCHITECT.
4. PRESSURE TREATED LUMBER (RED OR JACK PINE) No. 2 GRADE OR BETTER SHALL BE USED.
5. ALL NOTED BOARD DIMENSIONS ARE NOMINAL.
6. ALL END CUTS TO BE TREATED WITH WOOD PRESERVATIVE.
7. SONOTUBES ARE TO BE USED FOR ALL FOOTINGS TO MINIMIZE FROST HEAVE.
8. ALL HARDWARE AND FASTENERS TO BE HOT DIPPED GALVANIZED OR APPROVED EQUIVALENT.

ALL DIMENSIONS ARE IN MILLIMETRES UNLESS OTHERWISE NOTED



ACOUSTIC FENCING DETAILS

REVISION NO.: 1
REVISION DATE: DECEMBER 2025

C-505

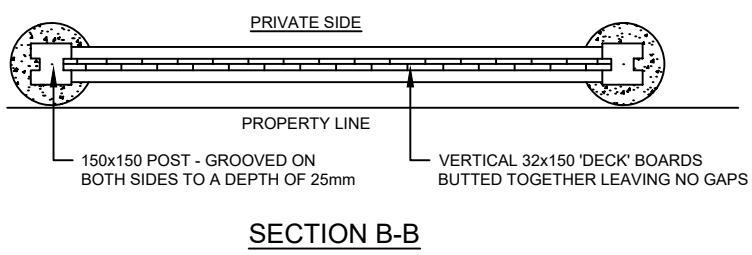
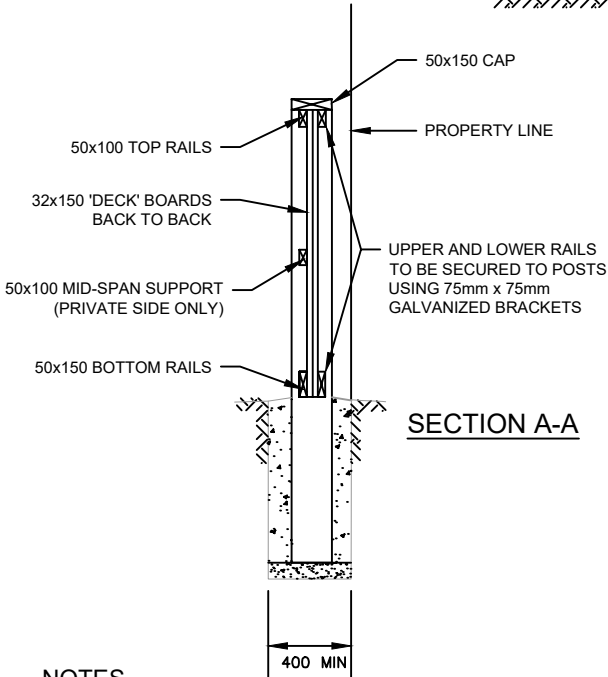
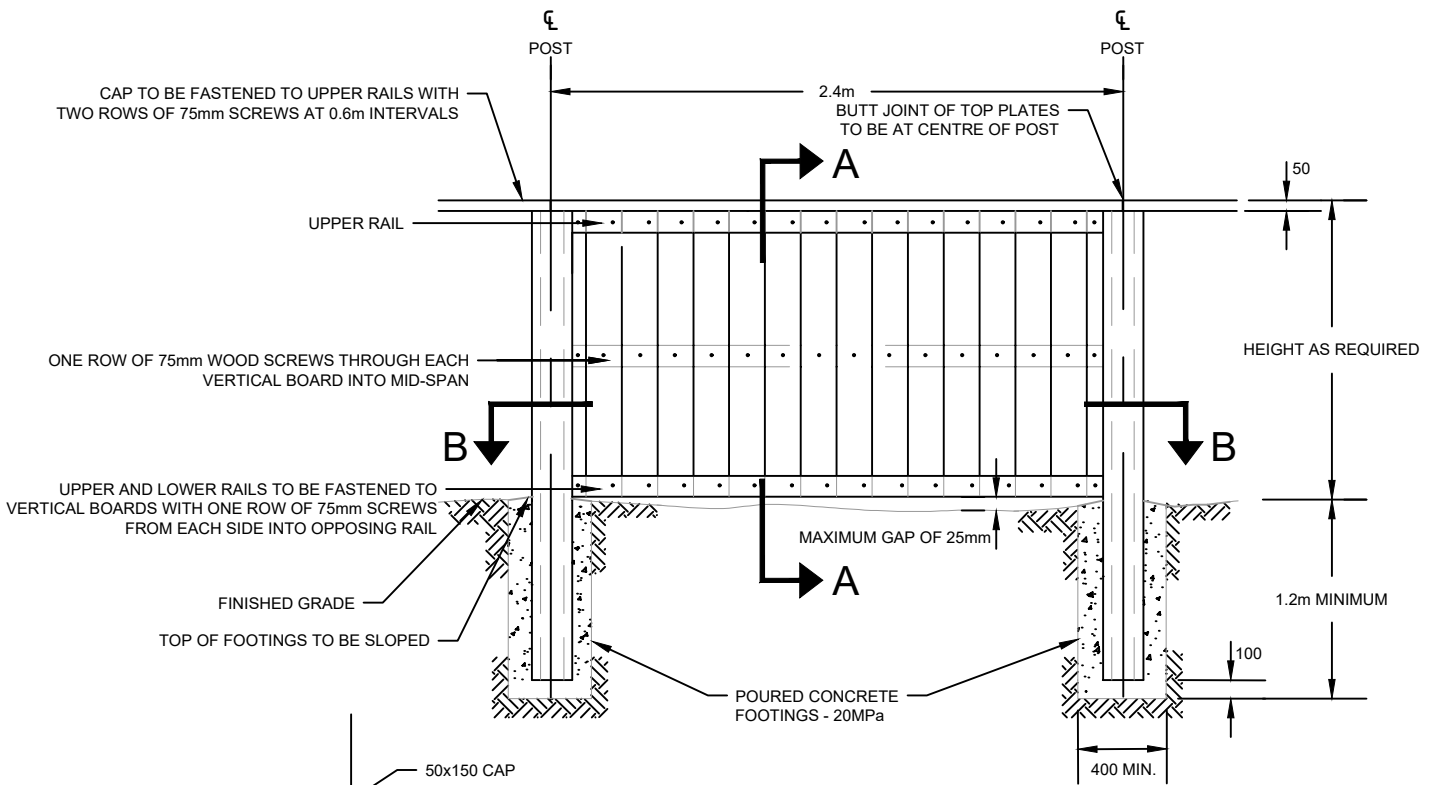

NOTES

1. ENGINEER TO VERIFY DESIGN STANDARD MEETS FENCE DENSITY / HEIGHT OF NOISE ATTENUATION REPORT.
2. FENCE, INCLUDING FOOTING, TO BE LOCATED ENTIRELY ON PRIVATE PROPERTY.
3. FENCES EXCEEDING 1.8m IN HEIGHT REQUIRE STAMPED DRAWINGS FROM A STRUCTURAL ENGINEER AND APPROVAL FROM A LICENSED ARCHITECT.
4. PRESSURE TREATED LUMBER (RED OR JACK PINE) No. 2 GRADE OR BETTER SHALL BE USED.
5. ALL NOTED BOARD DIMENSIONS ARE NOMINAL.
6. ALL END CUTS TO BE TREATED WITH WOOD PRESERVATIVE.
7. SONOTUBES ARE TO BE USED FOR ALL FOOTINGS TO MINIMIZE FROST HEAVE.
8. ALL HARDWARE AND FASTENERS TO BE HOT DIPPED GALVANIZED OR APPROVED EQUIVALENT.

ALL DIMENSIONS ARE IN MILLIMETRES UNLESS OTHERWISE NOTED



**ACOUSTIC FENCING DETAILS
(ABUTTING RAILWAYS/OPEN SPACE)**

REVISION NO.: 1
REVISION DATE: DECEMBER 2025

C-506

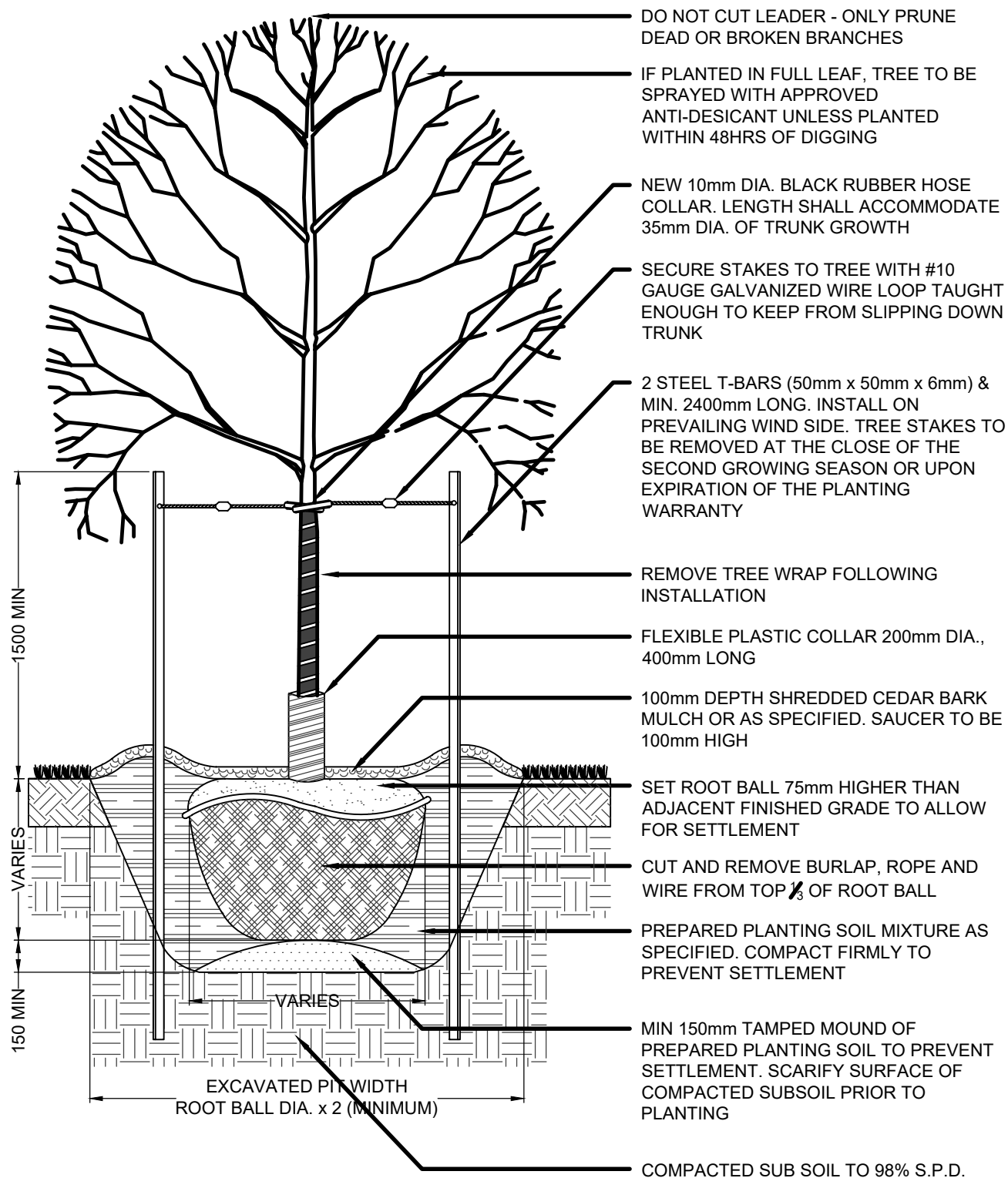

NOTES:

1. ALL DIMENSIONS ARE IN MILLIMETERS UNLESS OTHERWISE NOTED.
2. PREPARE PLANTING SOIL BY EVENLY MIXING 50% SANDY TOP SOIL, 25% PEAT MOSS AND 25% WELL ROTTED HORSE MANURE WITH 500q BONEMEAL. (OR NURSERY APPROVED TRIPLE MIX).
3. IF PLANTED IN FULL LEAF, TREE TO BE SPRAYED WITH APPROVED ANTI-DESICANT UNLESS PLANTED WITHIN 48HRS. OF DIGGING.

ALL DIMENSIONS ARE IN MILLIMETRES UNLESS OTHERWISE NOTED



**PLANTING DETAIL
(DECIDUOUS TREE)**

REVISION NO.: 1
REVISION DATE: DECEMBER 2025

C-508

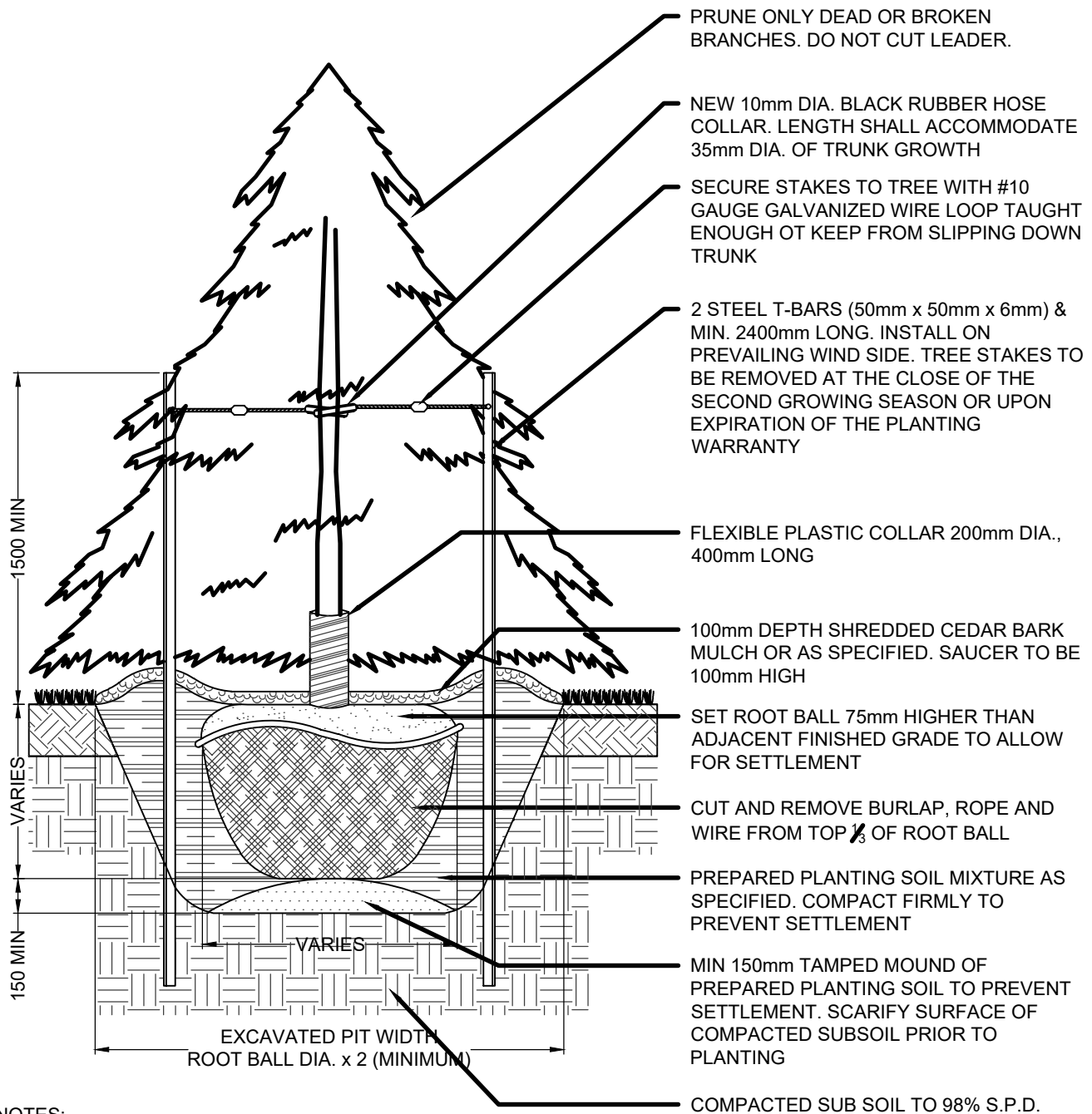

NOTES:

1. ALL DIMENSIONS ARE IN MILLIMETERS UNLESS OTHERWISE NOTED.
2. PREPARE PLANTING SOIL BY EVENLY MIXING 50% SANDY TOP SOIL, 25% PEAT MOSS AND 25% WELL ROTTED HORSE MANURE WITH 500g BONEMEAL. (OR NURSERY APPROVED TRIPLE MIX).
3. SEE SPECIFICATIONS FOR GENERAL MAINTENANCE.

ALL DIMENSIONS ARE IN MILLIMETRES UNLESS OTHERWISE NOTED

REVISION NO.: 1
 REVISION DATE: DECEMBER 2025



**PLANTING DETAIL
 (CONIFEROUS TREE)**

C-509

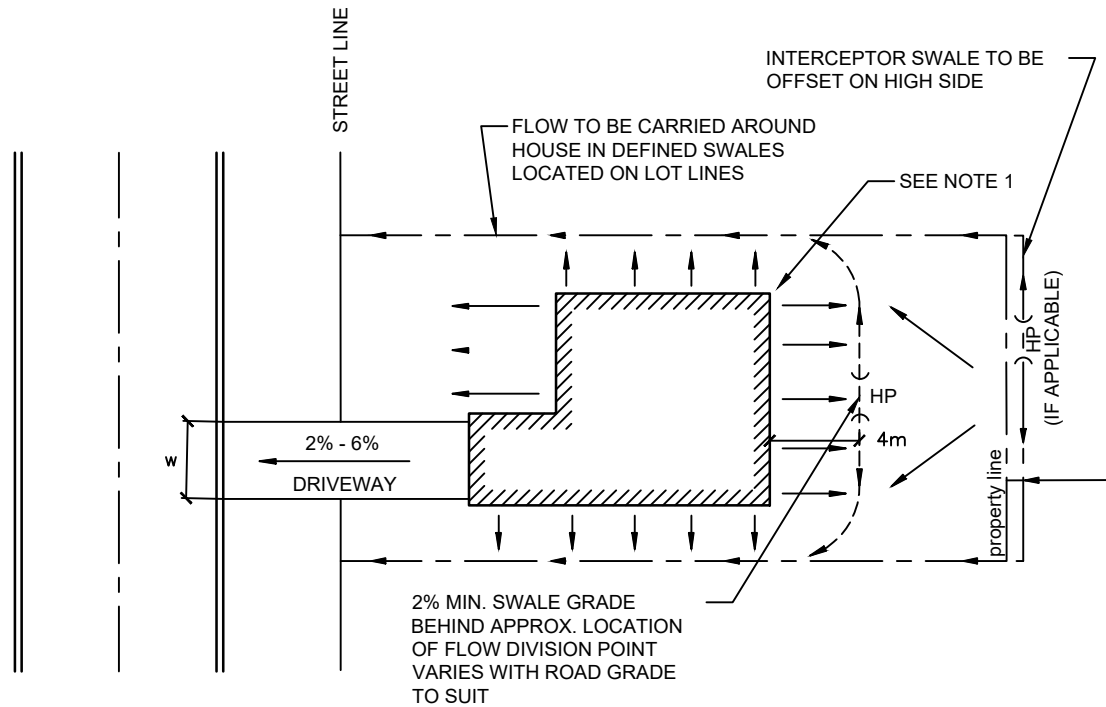

PLAN

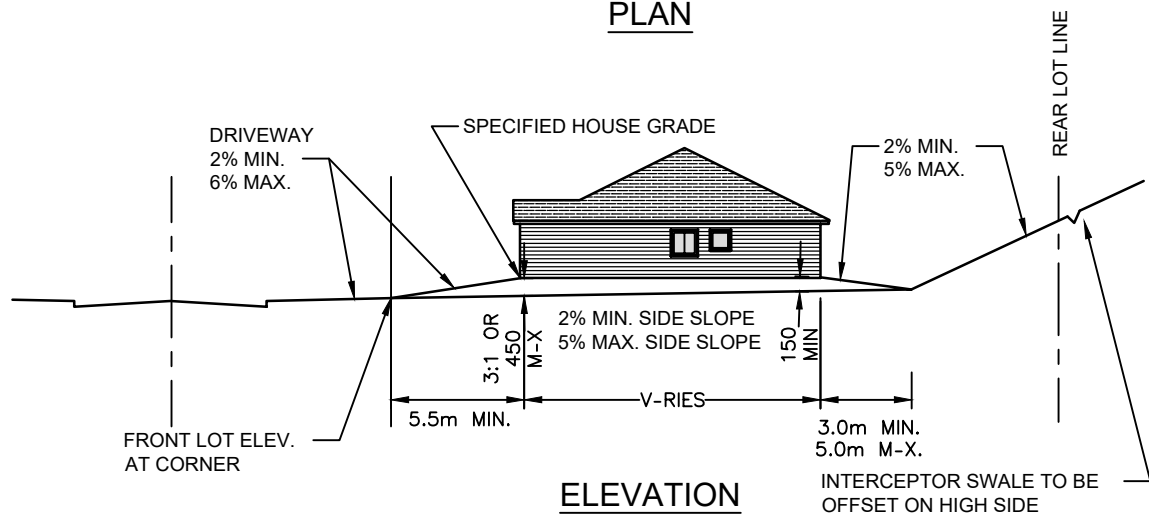

ELEVATION

NOTES

1. SPECIFIED HOUSE GRADE SHALL BE A MINIMUM OF 300mm ABOVE THE HIGHEST POINT LOT CORNER OR 450mm ABOVE THE LOWEST FRONT LOT CORNER, WHICHEVER IS HIGHER.
2. REFER TO SECTION 8 OF DESIGN STANDARDS.
3. WIDTH OF DRIVEWAY (w);
 - 3.1. SINGLE DETACHED - 4.6m TO 6.0m
 - 3.2. SEMI-DETACHED - 4.6m
 - 3.3. TOWNHOUSE - 3.0m
 - 3.4. (REFER TO SECTION 3 - ENTRANCES FOR MORE DETAILS)

ALL DIMENSIONS ARE IN MILLIMETRES UNLESS OTHERWISE NOTED

REVISION NO.: 1

REVISION DATE: DECEMBER 2025

Clarington

TYPICAL FRONT DRAINAGE LOT

C-801

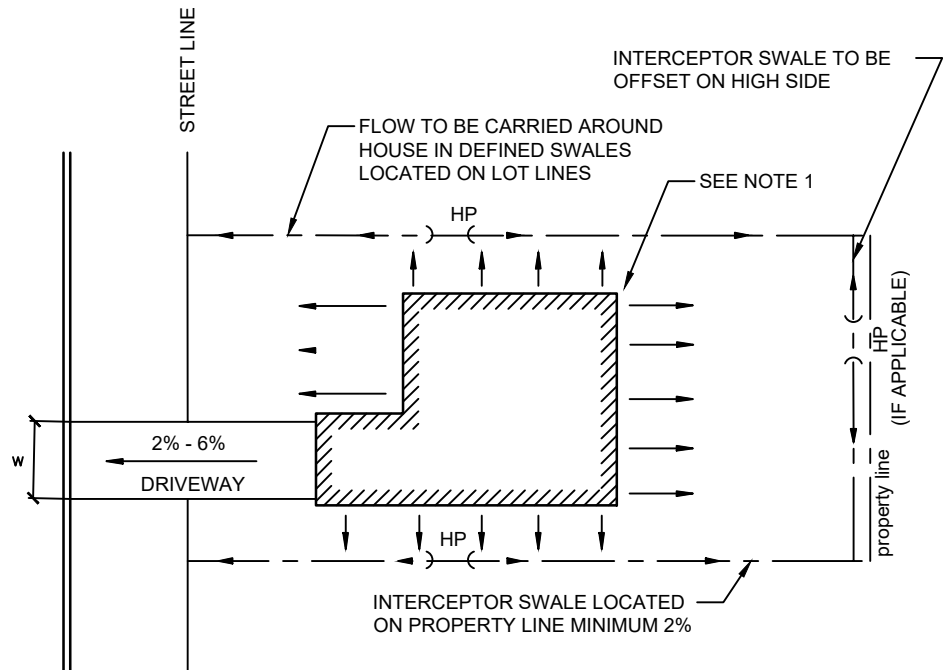

PLAN

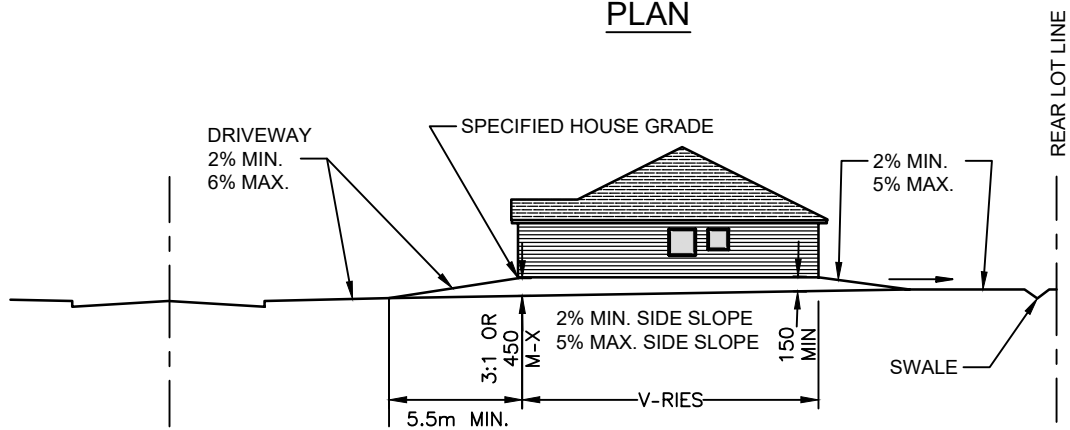

ELEVATION

NOTES

1. SPECIFIED HOUSE GRADE SHALL BE A MINIMUM OF 300mm ABOVE THE HIGHEST POINT LOT CORNER OR 450mm ABOVE THE LOWEST FRONT LOT CORNER, WHICHEVER IS HIGHER.
2. REFER TO SECTION 8 OF DESIGN STANDARDS.
3. WIDTH OF DRIVEWAY (w);
 - 3.1. SINGLE DETACHED - 4.6m TO 6.0m
 - 3.2. SEMI-DETACHED - 4.6m
 - 3.3. TOWNHOUSE - 3.0m
 - 3.4. (REFER TO SECTION 3 - ENTRANCES FOR MORE DETAILS)

ALL DIMENSIONS ARE IN MILLIMETRES UNLESS OTHERWISE NOTED



TYPICAL SPLIT DRAINAGE LOT

REVISION NO.: 1
REVISION DATE: DECEMBER 2025

C-802

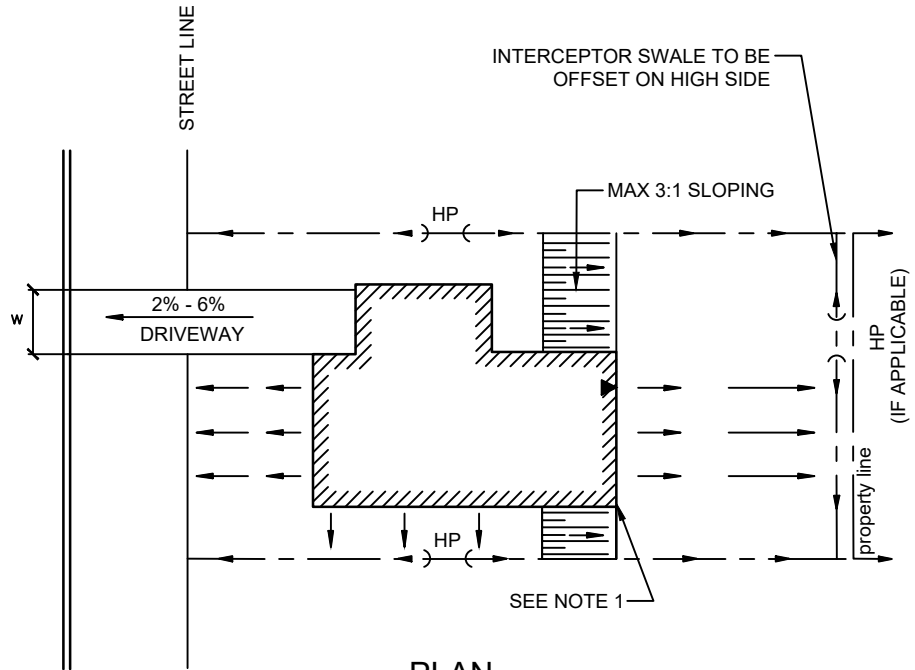

PLAN

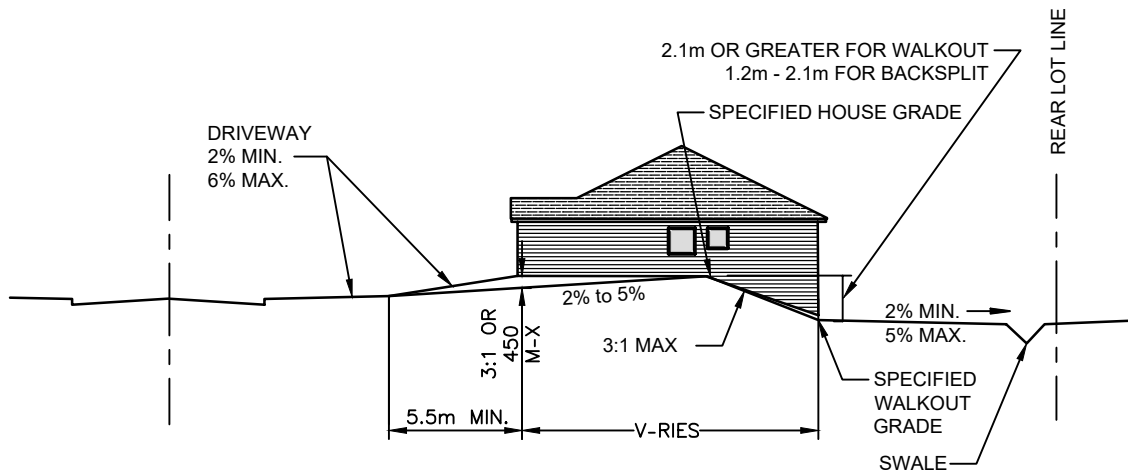

ELEVATION

NOTES

1. SPECIFIED HOUSE GRADE SHALL BE A MINIMUM OF 300mm ABOVE THE HIGHEST POINT LOT CORNER OR 450mm ABOVE THE LOWEST FRONT LOT CORNER, WHICHEVER IS HIGHER.
2. REFER TO SECTION 8 OF DESIGN STANDARDS.
3. WIDTH OF DRIVEWAY (w);
 - 3.1. SINGLE DETACHED - 4.6m TO 6.0m
 - 3.2. SEMI-DETACHED - 4.6m
 - 3.3. TOWNHOUSE - 3.0m
 - 3.4. (REFER TO SECTION 3 - ENTRANCES FOR MORE DETAILS)

ALL DIMENSIONS ARE IN MILLIMETRES UNLESS OTHERWISE NOTED



TYPICAL SPLIT DRAINAGE LOT FOR WALKOUT OR BACKSPLIT HOUSE

REVISION NO.: 1
REVISION DATE: DECEMBER 2025

C-803

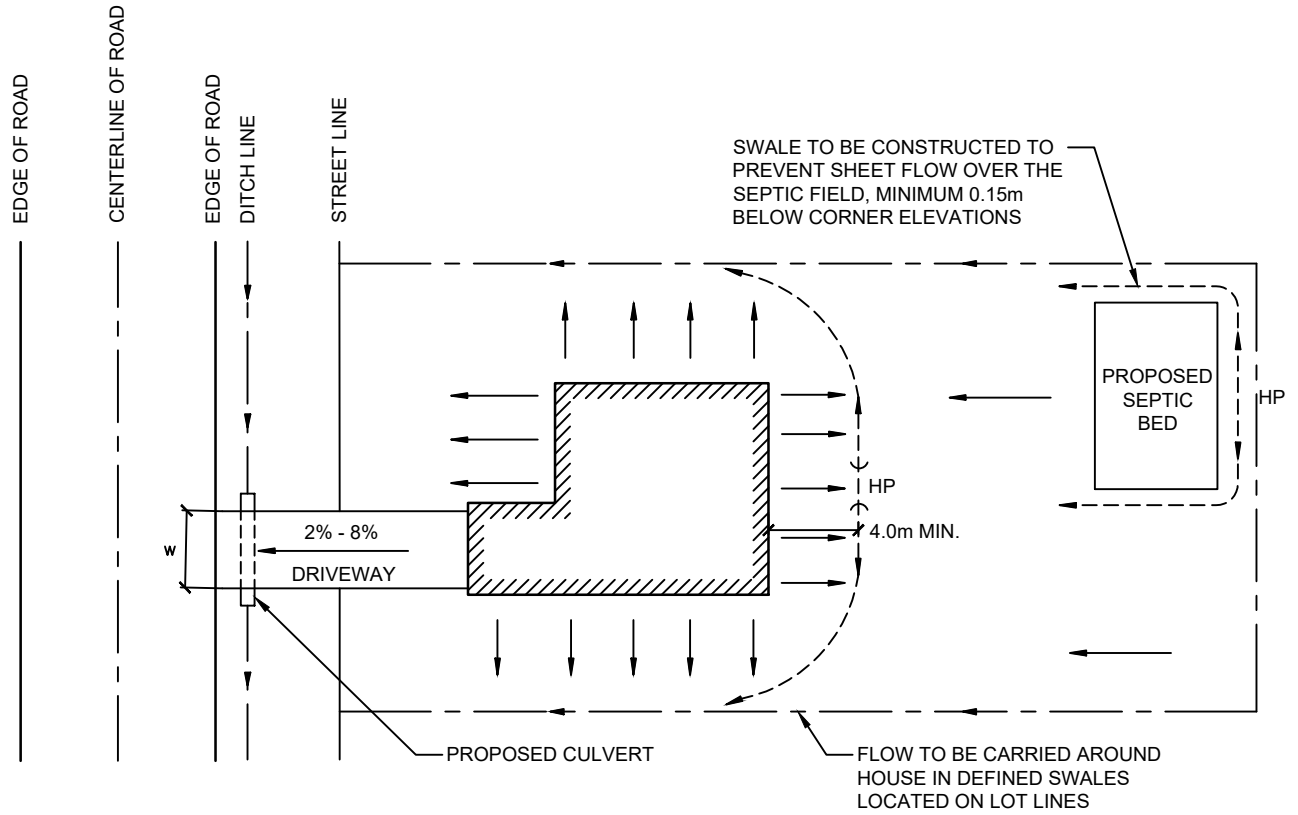

PLAN

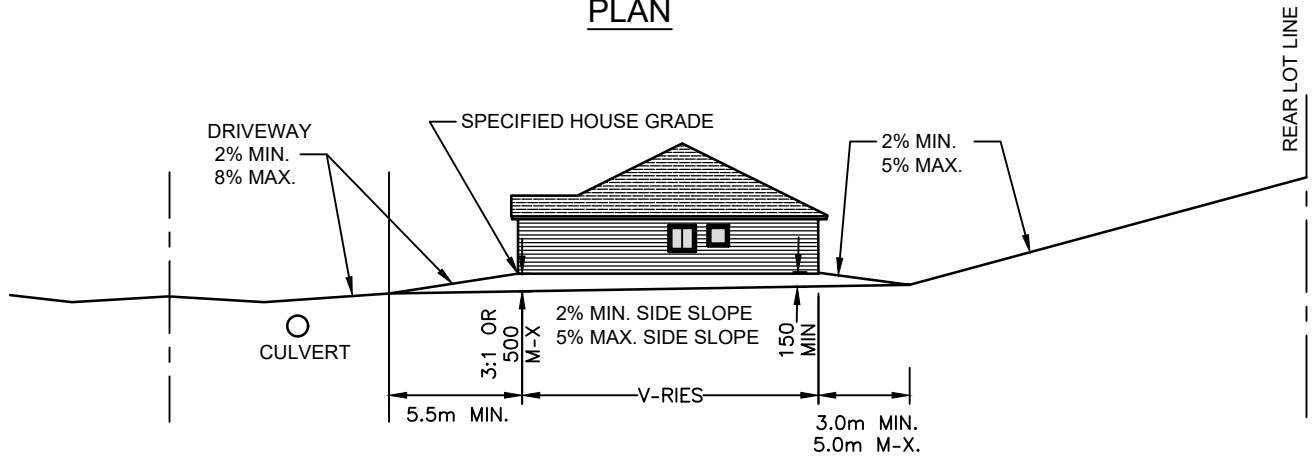

ELEVATION

NOTES

1. REFER TO SECTION 8 OF DESIGN STANDARDS FOR MORE DETAILS.
2. MAXIMUM WIDTH OF DRIVEWAY IS 6.0m. REFER TO SECTION 3 OF DESIGN STANDARDS

ALL DIMENSIONS ARE IN MILLIMETRES UNLESS OTHERWISE NOTED



**RURAL / ESTATE LOT
TYPICAL REAR TO FRONT DRAINAGE**

REVISION NO.: 1
REVISION DATE: DECEMBER 2025

C-804

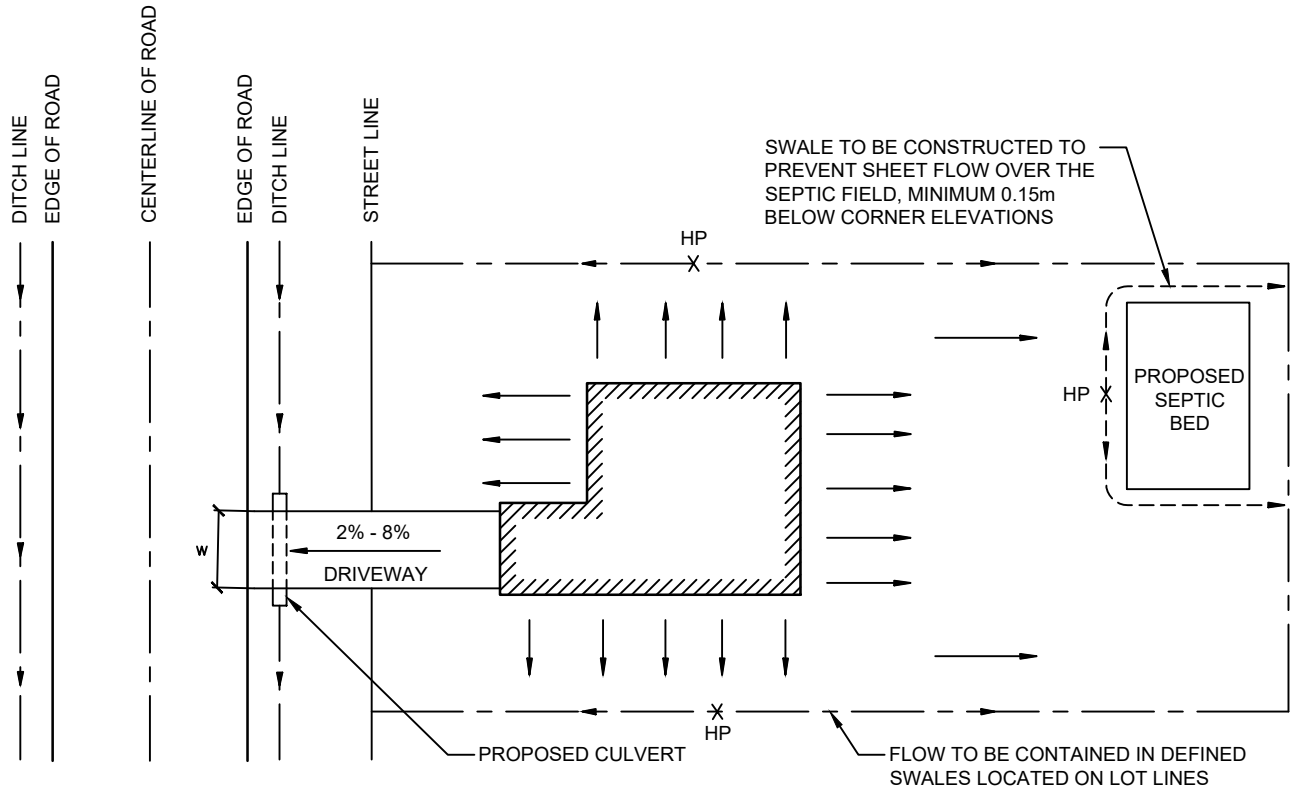

PLAN

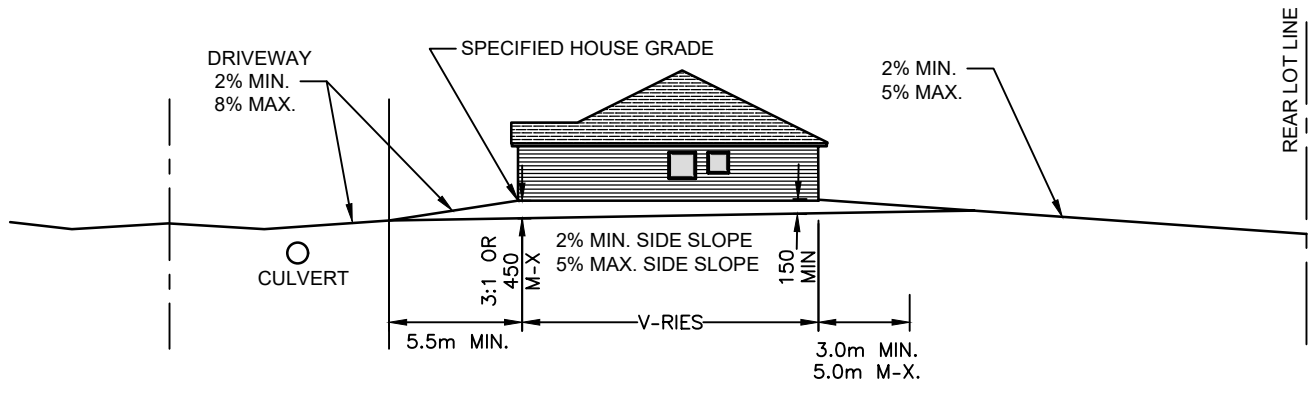

ELEVATION

NOTES

1. REFER TO SECTION 8 OF DESIGN STANDARDS FOR MORE DETAILS.
2. MAXIMUM WIDTH OF DRIVEWAY IS 6.0m. REFER TO SECTION 3 OF DESIGN STANDARDS

ALL DIMENSIONS ARE IN MILLIMETRES UNLESS OTHERWISE NOTED



RURAL / ESTATE LOT
TYPICAL SPLIT DRAINAGE

REVISION NO.: 1
REVISION DATE: DECEMBER 2025

C-805