

**STANDARD CURB AND GUTTER**

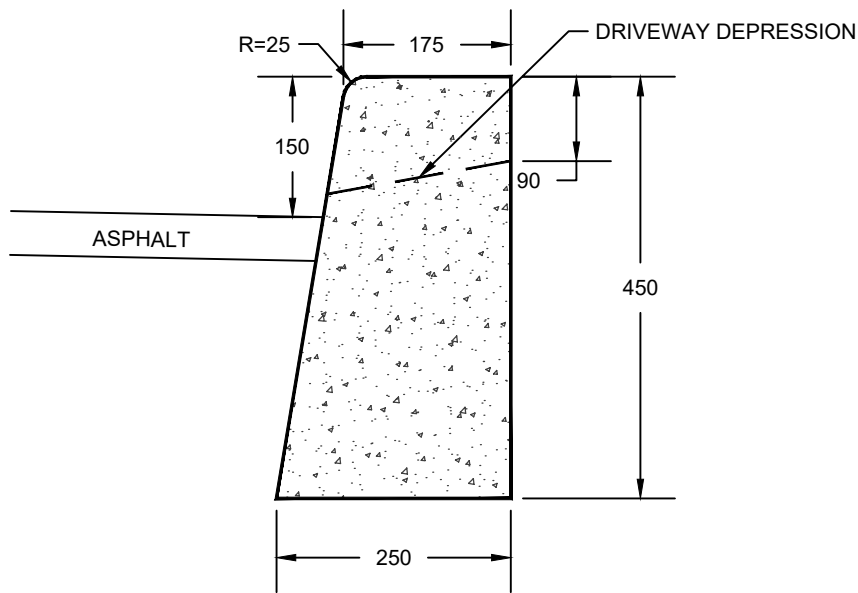

**BARRIER CURB**

**NOTES**

1. CONCRETE SHALL CONFORM TO OPSS MUNI 353 AND 1350 SPECIFICATIONS (32MPa, 5.0% TO 8.0% AIR).
2. CONTRACTION JOINTS TO BE SAWCUT EVERY 3.0m (MAXIMUM) AND TO BE 25% OF TOTAL DEPTH.
3. CURING COMPOUND TO BE APPLIED TO ALL EXPOSED SURFACES WITHIN HALF HOUR OF FINISHING. IF CONCRETE IS INITIALLY CURED WITH OTHER METHODS DUE TO THE WEATHER CONDITIONS, CURING COMPOUND SHALL BE APPLIED WITH 24 HOURS OF FINISHING.
4. ADDITIONAL WIDTH REQUIRED WHERE CURB IS ADJACENT TO SIDEWALK.
5. SEMI-MOUNTABLE CURB AND GUTTER SHALL BE AS PER OPSD 600.060.
6. COLD WEATHER PROTECTION SHALL BE USED WHEN DAY TIME TEMPERATURES ARE EXPECTED TO BE BELOW 5° CELSIUS DURING THE CURING PERIOD AS NOTED IN OPSS MUNI 904.

ALL DIMENSIONS ARE IN MILLIMETRES UNLESS OTHERWISE NOTED